



Brüel & Kjær Vibro

Product Specification

Compass 6000™ Condition Monitoring System

Hardware Module:

Condition Monitoring Interface VI-6080

- Hardware & support packages for turn-key operation of 8 to 48 measuring channels

Copyright © 2017 Brüel & Kjær Vibro GmbH

All rights to this technical documentation remain reserved.

Any corporeal or incorporeal reproduction or dissemination of this technical specification or making this document available to the public without prior written approval from Brüel & Kjær Vibro GmbH shall be prohibited. This also applies to parts of this technical specification.

Brüel & Kjær Vibro GmbH
Leydhecker Str. 10
64293 Darmstadt
Germany
Phone: +49 6151 428 0
Fax: +49 6151 428 10 00
info@bkvibro.com

Content

1	Product Overview	4
2	Product Introduction	5
	2.1 Application Modes	5
	2.2 Key Features	5
	2.3 Ordering of pre-installed Hardware Packages	5
3	VI-6080 Condition Monitoring Hardware Packages for up to 48 Channels	6
	3.1 Components of VI-6080 Hardware Packages	6
	3.2 Hardware Package Components & Ordering Information	7
	3.3 Condition Monitoring Interface VI-6080	7
	3.4 Signal Connection – Interface Accessories	7
	3.5 Compact Cabinets AC-2161, AC-2162 or DIN-Rail	8
	3.6 Power Supply	8
	3.7 Special Requirements	8
	2.8 Order Code VI-6080 Hardware Package	10
4	Support and Service Packages	11
5	Technical Data VI-6080	12
6	Notes	Error! Bookmark not defined.

1 Product Overview

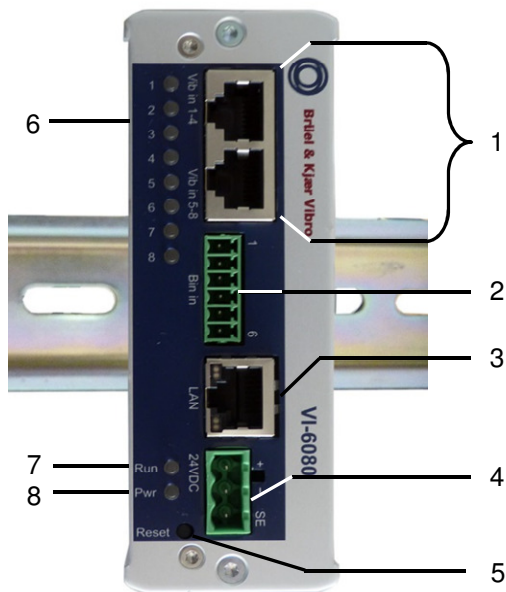

Connections

1. Vibration input (8-channels)
2. Binary input
3. LAN connection (network)
4. +24 VDC Power supply
5. Reset button

Status indicators

6. Channel LEDs (8 Channels)
7. Run LED
8. Power LED

Picture 1-1) Condition Monitoring Interface VI-6080 (mounted on DIN-Rail)

2 Product Introduction

The Condition Monitoring Interface VI-6080 is an interface for integrating existing Machinery Protection Systems (MPS) into a plant-wide condition monitoring solution or to install a stand-alone Condition Monitoring System (CMS) for individual machines or machine groups.

This is accomplished by streaming real-time vibration waveform data up to 20 kHz into the Compass 6000 CMS platform. Compass 6000 is analyzing, displaying and archiving the diagnostic results.

The pre-defined hardware & support packages are providing a complete bundle of all components to install and operate a turn-key solution for 8 to 48 measuring channels.

2.1 Application Modes

- Integrate existing MPS into a plant-wide CMS solution
- Stand-alone CMS with smart interface accessories for direct sensors input

2.2 Key Features

- Freely config. 8-channel VI-6080 interface devices are sampling vibration signals up to 20 kHz.
- 3-binary inputs for machine state information (Compass 6000 CMS Machine State monitoring)
- Direct access to buffered signal outputs of any installed MPS.
Easy to connect with BNC adapter cable AC-4703 or terminal connection via EQ-2672.
- Integrate CCS (Constant Current Supply) sensors with smart sensor supply accessories AC-4704, or -24 V sensor supply with AC-4705 to build a stand-alone CMS.
- Variable field installation via DIN-Rail mounting in existing cabinets or complete pre-installed in compact cabinets.

2.3 Ordering of pre-installed Hardware Packages

The VI-6080 packages can be ordered with different options depending on:

- Number of required channels
- Interfacing accessories
- Compact cabinets
(The input and output cabling strip design fulfills IP class 20. In case the Compact cabinets shall be used resp. mounted outside a special cable feedthrough design adaption is required.)
- Support packages for engineering, implementation, start-up, training & optimization.



3 VI-6080 Condition Monitoring Hardware Packages for up to 48 Channels

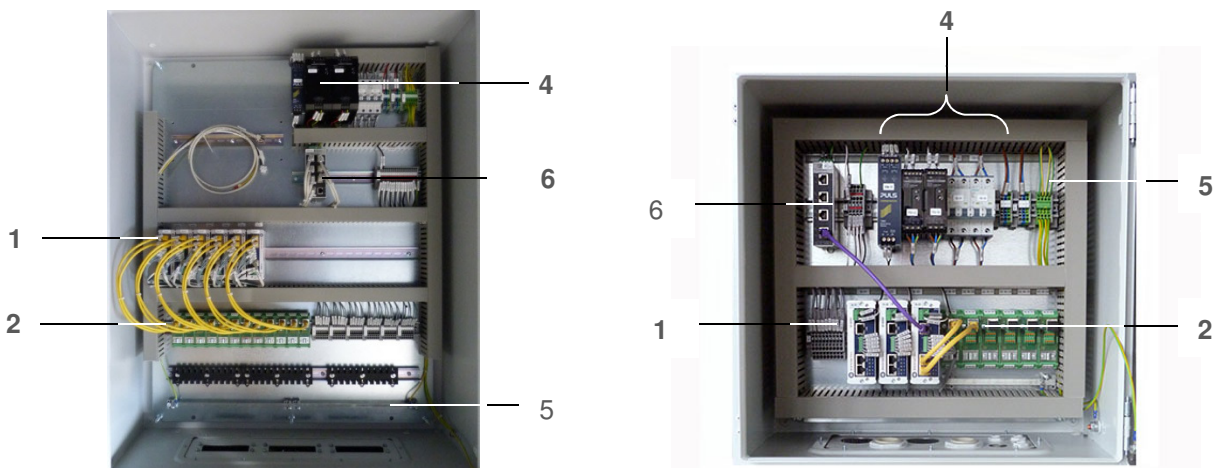

Picture 3-1) VI-6080 installed in a field cabinet: AC-2161 (left, 6x VI-6080 w. accessories, w/o optional PC) and AC-2162 (right, 3x I-6080 w. accessories). Cat-5e patch cables are not fully completed on the picture!

3.1 Components of VI-6080 Hardware Packages

Typical cabinet arrangement:

1. Condition Monitoring Interface VI-6080
2. Vibration input connectors (4 different types are available):
Connection to VI-6080 via Cat-5e patch cable
 - a. AC-4703 adapter cable (BNC) for buffered outputs
 - b. EQ-2672 mini patch panel for terminal connection
 - c. AC-4704 direct input of CSS supplied sensors
 - d. AC-4705 direct input for -24 V sensor supply (available soon)
3. Binary inputs (not shown)
4. Power supply arrangements:
 - a. Power supplies (single or redundant incl. redundancy module)
 - b. Circuit bracker
5. Protection earth
6. EQ2635 Ethernet switch to connect to network via Cat-5e patch cable

Optional component: Industrial PC



Picture 3-2) Optional industrial computer (picture shows type EQ2692-...) within large cabinet AC-2161 only.

3.2 Hardware Package Components & Ordering Information

Basic Units Channels	Signal Connectors	Compact Cabinets	Power supply Redundancy	Special requirements
VI-6080-SYS-aaCH/	b1-b2-b3-b4/	cc/	dd/	ee
→ No of channels	→ Connector for signals	→ Type of enclosure	→ Type of power supply	→ Other requirements

3.3 Condition Monitoring Interface VI-6080



- 8x AC/DC input channels – freely configurable (Vibration, Reference for Phase trigger/Rotational Speed, Process)
- 3x Binary input channels
- +24V DC Power supply

Order code: enter number of measuring channels 08, 16, 24, 32, 40, 48 (this results in quantity of VI-6080 units; 8 channels each)

aa

3.4 Signal Connection – Interface Accessories

Important Note:

The number of interface accessories are calculated automatically when entering **99** either in **b1** or **b2** or **b3** or **b4**
Within AC-2162 there is space for max. 3x AC-4704 resp. 3x AC-4705

3.4.1 AC-4703 Adapter Cable for BNC (4-channels)



Connect to BNC – e.g. buffered outputs of a Machinery Protection System (MPS).

Order code: enter quantity 01 to 12 of adapter cable AC-4703 (each 4-channels)

b1

3.4.2 EQ-2672 Mini Patch Panel (4-channels)



Connect open ended signal cable e.g. buffered outputs of a Machinery Protection System (MPS).



EN

Order code: enter quantity 01 to 12 of Mini-Patch-Panels EQ-2672 (each 4-channels) **b2**

3.4.3 AC-4704 Sensor Module for Direct Connection - CSS (4-channels)



The AC- 4704 connects constant current-supplied acceleration sensors (CCS-sensors, or CCLD, or ICP®) to a VI-6080 device.

Order code: enter quantity 01 to 12 of AC-4704 modules (each 4-channels) **b3**

3.4.4 AC-4705 Direct Sensor Connection for -24V supply (4-channels)

The AC-4705 is supporting sensors with -24 V (typical non-contacting displacement sensors) and allows direct connection to a VI-6080 device.

(available soon)

Order code: enter quantity of AC-4705 modules 01 to 12 (each 4-channels) **b4**

3.5 Compact Cabinets AC-2161, AC-2162 or DIN-Rail

- AC-2161 cabinet for 48 channels (max. 6 units VI-6080)
- AC-2162 cabinet for 24 channels (max. 3 units VI-6080)

Order code: enter **01** for AC-2161;
enter **02** for AC-2162;
enter **03** prepared for DIN-Rail mounting **cc**

3.6 Power Supply



Power supply for the entire VI-6080 hardware package. Power supply can be ordered in single or redundant version.

Order code: enter **01** for single power supply;
enter **02** for redundant power supply inclusive redundancy module **dd**

3.7 Special Requirements

Order code: enter **01** for no requirements;
enter **02** for special requirements and please specify in detail **ee**

3.7.1 Patch cable (for DIN rail mounting, please indicate number & length):

Cat-5e (grey/network & yellow/sensor signals) are available in these lengths:
0.25 m, 0.5 m, 1 m, 1.5 m, 2 m, 3 m, 5 m, 7.5 m, 10 m, 15 m, 20 m, 30 m

Note:

In case the VI-6080 hardware packages are ordered in Compact cabinets, all “internal” Patch cables required to connect the in-built interface accessories (mounted inside the cabinet) to the VI-6080 devices and further to an optional Industrial PC (AC-2161 only) are included (mounted).

All other required Patch cables, especially in case the DIN-Rail hardware package is selected, are not included and have to be ordered acc. Number, (color) and length separately! The color is used to distinguish the “signal type” (sensor or network), however the Patch cables are identical from design point of view.



2.8 Order Code VI-6080 Hardware Package

Code: VI-6080-SYS-

Number of Measuring Channels:	8	16	24	32	40	48	-aa CH
1 x VI-6080	•						08
2 x VI-6080		•					16
3 x VI-6080			•				24
4 x VI-6080				•			32
5 x VI-6080					•		40
6 x VI-6080						•	48

➤/ **aa**

Connection of Signals:	b1	b2	b3	b4	/b1-b2-b3-b4
AC-4703	•				00; 01-12 or 99 ¹
EQ-2672		•			00; 01-12 or 99 ¹
AC-4704			•		00; 01-12 or 99 ¹
AC-4705				•	00; 01-12 or 99 ¹

➤/ **b1 b2 b3 b4**

VI-6080 Cabinets & DIN rail	AC-2161	AC-2162	DIN-Rail	/cc
Cabinet up to 48 channels + optional: CMS Industrial PC	•			01
Cabinet up to 24 channels + without Condition Monitoring PC		•		02
for DIN rail mounting please indicate quantity & length of CAT-5e patch cable			•	03

➤/ **cc**

Power supply	01	02	/dd
Single power supply	•		01
Redundant power supply incl. redundancy module		•	02

➤/ **dd**

Special requirements	01	02	/ee
None	•		01
Yes, please specify individually		•	02

➤/ **ee**

Typical Examples (Order Codes): VI-6080-SYS-24CH /99-00-00-00/02/02/01
 VI-6080-SYS-40CH /07-03-00-00/01/01/01

¹99= number of units will be calculated automatically

4 Support and Service Packages

Sales Support for Planning & Engineering

Planning & Engineering

- Solution discovery to understand application and Condition Monitoring System (CMS) expectations
- Agree on CMS solution concept based on Compass 6000
- Define components & site preparation (e.g. field wiring, installation, IT)

The proposed support & service packages are providing a trouble-free start of the Compass 6000 Condition Monitoring System (CMS).

Execution Phases for all Hardware- and Software-Components

Content & Details

up to 24
Channels

up to 48
Channels

Software Configuration & Installation Review

- Review hardware & IT installation
(Set-up of computer hardware -PC or Server type- is not included)
- Database set up - allocate resource hardware channels (sensor inputs) to the database hierarchy (machine groups, machines and measurements)
- Implement base GUI & Condition Monitoring plots

Start-up & Training

- Start-up support
- Training of the operators & maintenance team
- Fine-tuning & Acceptance

Optimization

- System optimization (setup fine-tuning) after approx. 6 months operation

Order code:

VI-6080-Service-24CH

VI-6080-Service-48CH



5 Technical Data VI-6080

AC/DC Vibration Sensor Inputs

- Input voltage range-24 V to +24 V
- Input resistance220 kΩ

NOTE!

The VI-6080 is designed to interface to Buffered Outputs that fulfill the API 670 rev 5 requirements.

Frequency range (actual measurement range)

- Accelerometer sensor signals ...1 Hz to 20 kHz
- Velocity sensor signals. 1 Hz to 20 kHz
- Displacement sensor signals DC to 20 kHz
- Process signalsDC to 20 kHz

NOTE!

*For signal cable length between Buffered Output and Input of VI-6080 >100 meters
Max. frequency: 10 kHz!*

Sensitivity (configurable):

- Accelerometer (e.g. 100 mV/g)
- Velocity sensor (e.g. 100 mV/mm/s)
- Displacement sensor.... (e.g. 8 mV/μm)
- Process signals

Binary Inputs

- Response time < 10 ms
- Minimum current load (non-active signals)1 mA
- Signal status LOW:
Nominal input voltage.....0 V
Input voltage range -5 V to 5 V
- Signal status HIGH:
Nominal input voltage.....+24 V
Input voltage range 12 V to 35 V

Housing VI-6080 (DIN rail mounted)

- Dimensions (HxWxD)120 x 42 x 84 mm
- Protection classIP 20
- Operating Temperature -5 °C to +65 °C

Power supply single unit VI-6080

- Supply voltage+24V DC -15%/+15%
- Ripple 60 mV pp
- Temperature range..... -5 °C to +65 °C
- Power consumption per VI-6080 ..≈5 W

Time synchronization

- per VI-6080 deviceNTP

Approvals

- CE
- RCM mark
- UL

Technical Data for VI-6080 installations

Power supply of VI-6080 packages

- Single phase 100 to 240 VAC
..... 90 to 350 VDC

Power consumption

- AC-2161 cabinet 48 channels: max. 240 W
- AC-2162 cabinet 24 channels: max. 60 W

Space requirements

- AC-2161 Cabinet (HxWxD) 1000 x 800 x 300 mm
- AC-2162 Cabinet (HxWxD) 500 x 500 x 300 mm
- DIN Rail mounting:
Space requirements depend on layout on DIN rail mounting! Estimation made for redundant power supplies without space requirement for optional (CMM) PC!
- 1 unit VI-6080 approx.: 450 x 160 mm.
- 2 units VI-6080 approx.: 600 x 160 mm
- 3 units VI-6080 approx.: 750 x 160 mm
- 4 units VI-6080 approx.: 900 x 160 mm

- 5 units VI-6080 approx.: 1050x160 mm
- 6 units VI-6080 approx.: 1200x160 mm

Shipping weights for complete hardware packages with max. equipment configuration:

- Components DIN Rail mounting, 48 channels approx. 10 kg
- Cabinet AC-2162, 24 channels approx. 30 kg
- Cabinet AC-2161, 48 channels approx. 75 kg

Environmental specifications -5°C to 65°C

Protection class **IP20**

Contact

Brüel und Kjaer Vibro GmbH

Leydheckerstrasse 10

64293 Darmstadt

Germany

Phone: +49 6151 428 0

Fax: +49 6151 428 1000

www.bkvibro.com

Condition Monitoring Interface VI-6080 • BPS0145-EN-20 • © Brüel & Kjaer Vibro • Technical alterations reserved!