



Injection Molding & Plastics

3D Measuring Techniques for Industrial Injection Molding Processes

- 3D shape and dimension inspection
- Tool making and electrode production
- Assembly analysis and load tests

Quality Control

in Plastic & Injection Molding Process Chains

In plastics engineering, 3D metrology supports and speeds up all phases in injection molding, blow molding and thermoforming processes: from prototype & tool construction to first article inspection reports up to assembly analysis and load testing.

ATOS is an optical 3D coordinate measuring system allowing non-contact measurements of complete surfaces of prototypes, electrodes, tools and injection molded parts regardless of the object size. In contrast to tactile measuring techniques, this method even captures complex freeform contours quickly and completely.

Injection molding process chain

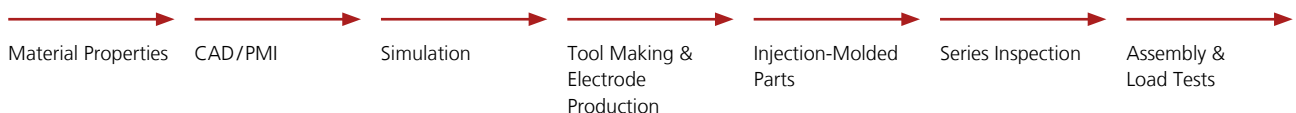

Full-field surface measurements guarantee a faster first article inspection and targeted tool correction, thereby reducing production lead times. For the production-accompanying quality control, both the measurements and the entire evaluation process can be automated.

Over 14,000 System Installations Worldwide

Automotive manufacturers: Audi, Bentley, BMW, Chrysler, Daihatsu, Daimler, Fiat, Ford, General Motors, Honda, Hyundai, Jaguar Land Rover, Mitsubishi, Nissan, Opel, Porsche, Renault, Škoda, Subaru, Suzuki, Tata, Toyota, Vauxhall, Volkswagen, Volvo, ...

Automotive suppliers: Autoliv, Automotive Lighting, Bosch, Bridgestone, Brose, Continental, Delphi, Dräxlmaier, Faurecia, Goodyear, Grupo Antolin, Hella, Johnson Controls, Key Plastics, Montaplast, Polytec, Promens Zevenaar, Röchling, Schaeffler, Takata, Vibroacoustic, Vredestein, ...

Consumer goods: adidas, BSH, Busch-Jäger, Canon, Electrolux, Fischerwerke, Gillette, Green Point, Hilti, Hitachi, Huawei, Lego, LG, Makita, Mattel, Nike, Pioneer, Playmobil, Procter & Gamble, Samsung, Sharp, Sony, Stanley Black & Decker, Stihl, YKK Zipper, ...

Medical engineering: Altay Scientific, Biomet, Celon Pharma, Cochlear, Coloplast, Coopdech, Cyberdyne, Dentsply, Edap TMS, Fresenius Kabi, Gerresheimer, Knudsen Plast, Maquet, Nobel Biocare, New Deantronics, Novo Nordisk, Otto Bock Health Care, Planmea, Promed, Radiometer, Sarstedt, SHL Group, Stratec Biomedical, Synbone, Synthes, Terumo, ...

Material manufacturers: 3M, BASF, Bayer, Daikin, DIK Kautschuktechnologie, Faserinstitut Bremen, Fraunhofer (ICT), Hutchinson, IMA, Inegi, Kömmerling, Lanxess, Polymer Competence Center, RWTH Aachen (IKV), Sabic, Solvay, Sumitomo, Toray, ...

GOM – Precise Industrial 3D Metrology

GOM develops, produces and distributes software, machines and systems for industrial and automated 3D coordinate measuring technology and 3D testing based on latest research results and innovative technologies.

With more than 60 sites and an employee network of more than 1,000 metrology specialists, GOM guarantees professional advice as well as support and service to operators on-site in their local languages. In addition, GOM shares knowledge on processes and measurement technology in training courses, conferences and application-based workshops.

GOM has been developing measuring technology in Braunschweig since 1990. In the respective research and development departments, more than 100 engineers, mathematicians and scientists shape the measuring technology of the present and the future.

Today, more than 14,000 system installations improve product quality and accelerate product development and manufacturing processes for international companies in the automotive, aerospace and consumer goods industries, their suppliers as well as many research institutes and universities.



GOM headquarters in Braunschweig, Germany



Material Properties

Applications – Material manufacturers use testing procedures to determine material properties and create material cards. Knowing the plastic's properties is a reliable basis for an adequate component design (CAD), the development of a functioning tool as well as for a realistic simulation (CAE) and the optimization of product variants, tool layout and injection molding processes.

- Tensile tests, pressure tests, shear and bending tests
- Anisotropy and Young's modulus
- Flow curve
- N-value, R-value
- Comparison and choice of materials

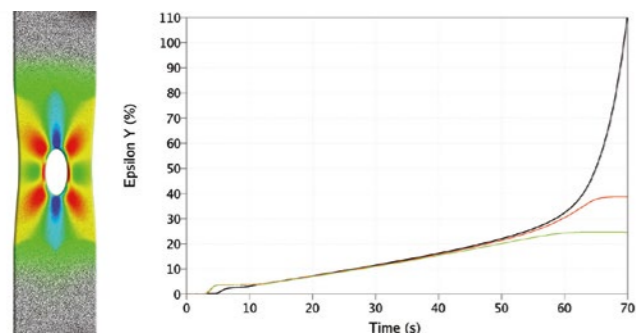

Benefit – Determining the material behavior such as elastic and plastic strain values as well as the effect of fiber direction and fiber length optimizes the material selection. Reproducible determination of material characteristics for new compounds, identification of quality variations within a batch of material and incoming goods inspection.

Measuring systems and evaluation
ARAMIS, GOM Correlate

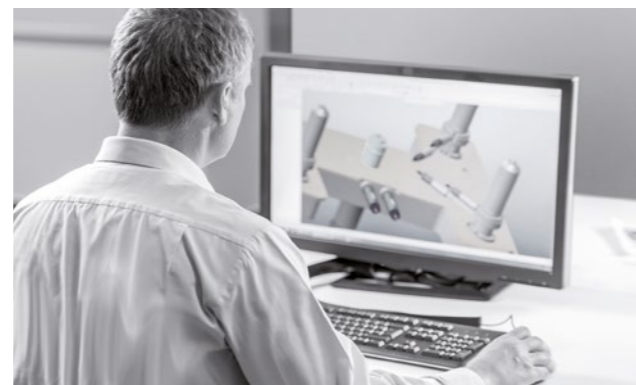

CAD/PMI – Design

Applications – If the CAD model of a part has been provided with inspection features already during design, the 3D measurement planning and inspection can be performed in a drawing-free process directly on the PMI data set (import and evaluation of FTA/MBD data). Furthermore, the full-field geometry acquisition allows refeeding and adapting component and tool geometries into existing CAD data if a tool correction is necessary (advanced CAD modeling).

- Inspection planning on CAD (PLM)
- PMI interface (CATIA, PRO-E, NX)
- Compensation of warpage and shrinkage
- Camber of tool, incorporation into CAD

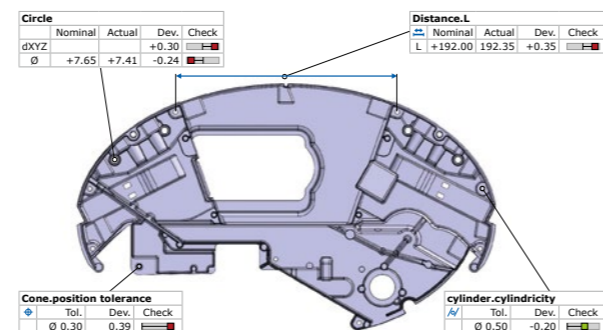

Benefit – The direct import and evaluation of PMI data including tolerance specifications from 3D design models accelerates new product development processes and production processes by 3D measurement planning on the CAD data set or via FTA/MBD data prior to the component production. At the same time, the inspection data is available throughout the complete PLM ensuring a continuous control (central component management).

Measuring systems and evaluation
ATOS, GOM Inspect

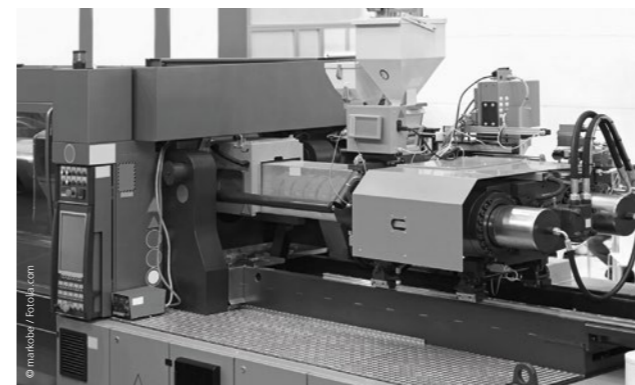

CAE – Simulation & Verification

Applications – Simulation serves to compute and visualize the mold filling, sprue, holding pressure, temperature control and filling time of the injection-molded part. The purpose is to prevent errors and to optimize the use of materials, the cycle time and the machine size by prognosticating the material behavior and process parameters. The complete surface of the geometry is numerically compared to simulated or real component measurements.

- Limitation of warpage, shrinkage and material thickness
- Processing of mesh simulation data
- Mesh processing (refining, hole filling, repair, ...)
- Comparison of simulated and real components
- Verification of injection molding simulations

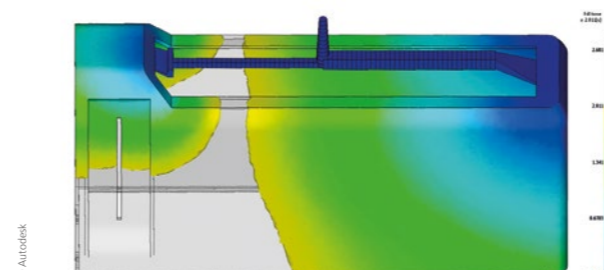

Benefit – Support in the choice of materials, assessment of tools and optimization of process parameters. The verification of FE simulations serves for knowledge building and guarantees an increased reliability of numerical simulations. The trend analysis based on simulated parameters ensures reliability when making decisions regarding the further process (finding best mesh).

Measuring systems and evaluation
ATOS, ARAMIS, GOM Inspect

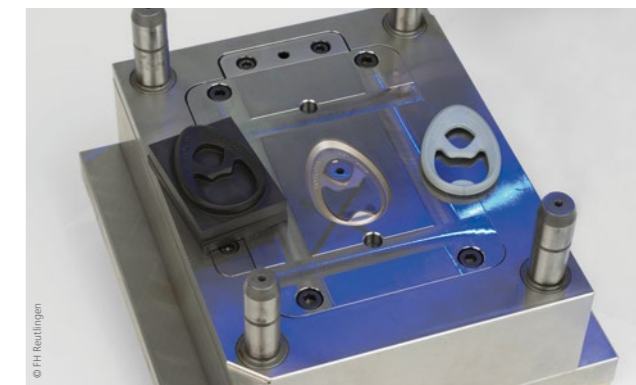

CAD/CAM – Tools & Electrodes

Applications – 3D digitizing saves time and costs during tool and electrode production and maintenance. Process control at an early stage reduces correction loops, especially for multiple cavities. Nominal/actual comparison serves to control the individual steps during CNC processing of the tool. In try-out, 3D measuring data allows a specific tool correction and a lower material input.

- Optimization of multiple cavities
- Check eroding areas and create electrodes
- Targeted tool correction
- Wear control
- Dynamic 3D motion analysis

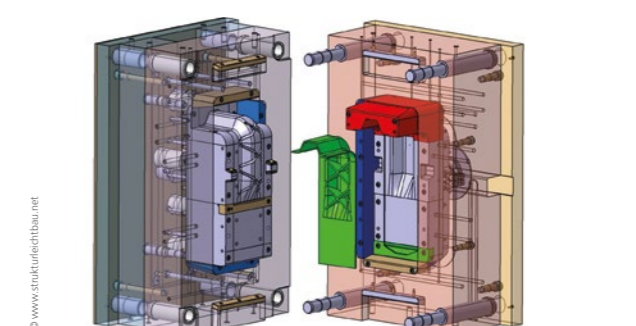

Benefit – Warpage and deformation measurements of plastic parts during the mold validation lead to a targeted tool optimization. The virtual assembly analysis serves for the inspection of contact surfaces and tool offset. Dynamic 3D motion analyses of the tool help to recognize relative movements between the tool halves with various injection parameters (mold breathing).

Measuring systems and evaluation
ATOS, ARAMIS



Injection-Molded Parts & Initial Sample Testing

Applications – Full-field shape & dimension analyses including complete measuring and inspection reports (FAI) ensure that the functionality is secured and optical requirements are met, and allows the tension-free mounting of a component. The first article inspection can be carried out based on the measuring plan (CMM inspection), CAD model or PMI data set with features such as geometric dimensioning and tolerancing (GD&T). No area of the component remains unchecked.

- Inspection of geometry & material thickness
- Sink marks, warpage and shrinkage (local/global)
- Camber of tool
- Cavity comparison
- Geometric dimensioning and tolerancing, GPS

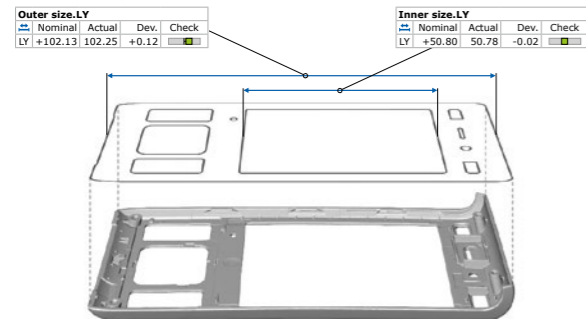

Benefit – The easily understandable results enable a fast determination of correction values for the tool geometry (sink marks, warpage and shrinkage) as well as for machine and process parameters (holding pressure, temperature control, filling time ...). Software features such as surface defect map, silhouette and cluster evaluation facilitate checks e.g. of surface defects.

Measuring systems and evaluation
ATOS, GOM Inspect



Production & Series Inspection

Applications – In series-accompanying manufacturing control, automated, production-related and mobile measuring cells reduce scrap and rework time. Parts do not have to be transported to remote measuring rooms. The programming, including the kinematics of the robot paths and the inspection planning, can be realized offline in the virtual measuring room (VMR) on the CAD, while the measuring cell remains productive.

- Automated quality control
- Inspection reports at the production plant
- Trend analysis in real time (cause/progress)
- Statistical analysis and export (Cp/Cpk/Pp/Ppk/Min/Max/Avg/Sigma)

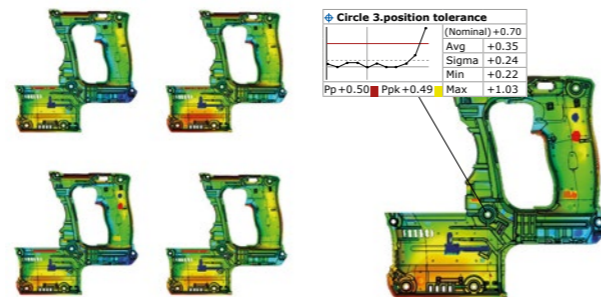

Benefit – Turnkey measuring cells are location-flexible. They can be used directly in production and deliver fast measuring results. Automated measuring cells with integrated operational safety are ready for use in short time. The cells are operated by shop floor workers and are adaptable for prototyping, tool making, analysis, production and assembly.

Measuring systems and evaluation
ATOS ScanBox



Assembly & Load Tests

Applications – Full-field or point-based online 3D tracking allows the alignment and positioning of physical components relative to each other (optical gauge) and an optimum virtual alignment to be transferred into the real physical world. As a result, the mounting and installation as well as deformation and gap sizes can be checked. Test facilities such as climatic chambers and crash test stands serve to examine the life cycle of products.

- Virtual assembly
- Flush and gap analysis
- Deformation analysis
- Endurance tests and crash tests

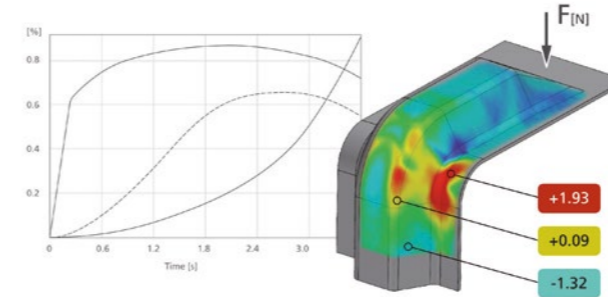

Benefit – Fast assembly analysis for prototypes, Meisterbock & Cubing as well as for series by real-time representation. Thermal and mechanical testing of the part concerning the functionality, safety, durability and aesthetics serves to optimize the choice of materials and the component design. As the measuring systems are easy to handle and require less setup time, conventional fixtures are being replaced.

Measuring systems and evaluation
ATOS, ARAMIS



ATOS
Industrial Optical 3D Digitizer



ATOS ScanBox
Optical 3D Coordinate Measuring Machine



ARAMIS
3D Motion and Deformation Sensor

GOM Inspect
Evaluation Software for 3D Measuring Data

GOM Correlate
Evaluation Software for 3D Testing

gom

www.gom.com