

# Mounting Instructions

English



## T10F

Hottinger Baldwin Messtechnik GmbH  
Im Tiefen See 45  
D-64239 Darmstadt  
Tel. +49 6151 803-0  
Fax +49 6151 803-9100  
info@hbm.com  
www.hbm.com

Mat.: 7-2001.1510  
DVS: A0608-17.0 HBM: public  
01.2018

© Hottinger Baldwin Messtechnik GmbH.

Subject to modifications.  
All product descriptions are for general information only.  
They are not to be understood as a guarantee of quality or  
durability.

<b>1</b>	<b>Safety instructions</b> .....	<b>6</b>
<b>2</b>	<b>Markings used</b> .....	<b>10</b>
2.1	The markings used in this document .....	10
2.2	Symbols on the product .....	11
<b>3</b>	<b>Torque flange versions</b> .....	<b>12</b>
<b>4</b>	<b>Application</b> .....	<b>13</b>
<b>5</b>	<b>Structure and mode of operation</b> .....	<b>14</b>
<b>6</b>	<b>Mechanical installation</b> .....	<b>15</b>
6.1	Conditions on site .....	16
6.2	Installation orientation .....	16
6.3	Installation options .....	17
6.3.1	Installation without dismantling the antenna ring .....	18
6.3.2	Installation with subsequent stator mounting .....	19
6.3.3	Installation example with couplings .....	20
6.3.4	Installation example with joint shaft .....	20
6.4	Mounting the rotor .....	21
6.5	Mounting the stator .....	24
6.6	Installing the clamp fixture .....	26
6.7	Fitting the slotted disc (speed measuring system) .....	29
6.8	Aligning the stator (speed measuring system) .....	30
<b>7</b>	<b>Electrical connection</b> .....	<b>32</b>
7.1	General information .....	32
7.1.1	FCC and IC compliant installation for US and Canada installation only .....	32
7.2	Shielding design .....	34
7.3	Option 2, code KF1 .....	35
7.3.1	Adaptation to the cable length .....	35
7.4	Option 2, code SF1/SU2 .....	37
7.5	Supply voltage .....	39

<b>8</b>	<b>Calibration</b> .....	<b>41</b>
8.1	Calibration option 2, code KF1 .....	41
8.2	Calibration option 2, code SF1/SU2 .....	41
<b>9</b>	<b>Settings</b> .....	<b>43</b>
9.1	Torque output signal, code KF1 .....	44
9.2	Torque output signal, code SF1/SU2 .....	44
9.3	Setting up the zero point .....	44
9.4	Functional testing .....	45
9.4.1	Power transmission .....	45
9.4.2	Aligning the speed module .....	46
9.5	Setting the pulse count .....	47
9.6	Vibration suppression (hysteresis) .....	48
9.7	Form of speed output signal .....	49
9.8	Type of speed output signal .....	50
<b>10</b>	<b>Loading capacity</b> .....	<b>51</b>
10.1	Measuring dynamic torque .....	51
<b>11</b>	<b>Maintenance</b> .....	<b>53</b>
11.1	Speed module maintenance .....	53
<b>12</b>	<b>Dimensions</b> .....	<b>54</b>
12.1	Rotor dimensions .....	54
12.2	Stator dimensions .....	56
12.3	Mounting dimensions .....	58
<b>13</b>	<b>Order numbers, accessories</b> .....	<b>60</b>
<b>14</b>	<b>Specifications</b> .....	<b>62</b>
<b>15</b>	<b>Supplementary technical information</b> .....	<b>70</b>
15.1	Output signals .....	70
15.1.1	Output MD torque (connector 1) .....	70
15.1.2	Output N: Speed (connector 2) .....	71
15.1.3	Connector 2, double frequency, stat. direction of rotation signal ..	72

15.2	Axial and radial run-out tolerances .....	73
15.3	Additional mechanical data .....	74

# 1 Safety instructions

## FCC Compliance & Advisory Statement



### Important

*Any changes or modification not expressly approved by the party responsible for compliance could void the user's authority to operate the device. Where specified additional components or accessories elsewhere defined to be used with the installation of the product, they must be used in order to ensure compliance with FCC regulations.*

This device complies with Part 15 of the FCC Rules. Operation is subject to the following two conditions: (1) this device may not cause harmful interference, and (2) this device must accept any interference received, including interference that may cause undesired operation.

The FCC identifier or the unique identifier, as appropriate, must be displayed on the device.

Model	Measuring range	FCC ID	IC
T10S2	50 Nm, 100 Nm	2ADAT-T10S2TOS6	12438A-T10S2TOS6
T10S3	200 Nm		
T10S4	500 Nm, 1 kNm		
T10S5	2 kNm, 3 kNm		
T10S6	5 kNm, 10 kNm		



Fig. 1.1 Location of the label on the stator of the device

The preferred position of the FCC label is on the type plate. If this is not possible for reasons of space, the label can be found on the rear of the stator housing.

**Model: T10S2**

**FCC ID: 2ADAT-T10S2TOS6**

**IC: 12438A-T10S2TOS6**

This device complies with part 15 of the FCC Rules. Operation is subject to the following two conditions: (1) This device may not cause harmful interference, and (2) this device must accept any interference received, including interference that may cause undesired operation.

Label example with FCC ID and IC number

### Industry Canada IC

This device complies with Industry Canada standard RSS210.

This device complies with Industry Canada license-exempt RSS standard(s). Operation is subject to the following two conditions: (1) this device may not cause interference, and (2) this device must accept any interference, including interference that may cause undesired operation of the device.

*Cet appareil est conforme aux normes d'exemption de licence RSS d'Industry Canada. Son fonctionnement est soumis aux deux conditions suivantes : (1) cet appareil ne doit pas causer d'interférence et (2) cet appareil doit accepter toute interférence, notamment les interférences qui peuvent affecter son fonctionnement.*



## Important

*Usage/Installation in the USA and Canada requires an EMI suppressor. Please refer to chapter 7.1.1, page 32.*

### Designated use

The T10F torque flange is used exclusively for torque and rotation speed measurement tasks, and directly associated control and regulatory tasks. Use for any additional purpose shall be deemed to be *not* as intended.

In the interests of safety, the transducer should only be operated as described in the Operating Manual. It is also essential to comply with the legal and safety requirements for the application concerned during use. The same applies to the use of accessories.

The transducer is not a safety element within the meaning of its designated use. Proper and safe operation of this transducer requires proper transportation, correct storage, assembly and mounting, and careful operation.

### General dangers of failing to follow the safety instructions

The transducer corresponds to the state of the art and is failsafe. The transducer can give rise to remaining dangers if it is inappropriately installed and operated by untrained personnel.

Everyone involved with mounting, starting up, maintaining, or repairing the transducer must have read and understood the Operating Manual and in particular the technical safety instructions.

### Residual dangers

The scope of supply and performance of the transducer covers only a small area of torque measurement technology. In addition, equipment planners, installers and operators should plan, implement and respond to the safety engineering considerations of torque measurement technology in such a way as to minimize remaining dangers. On-site regulations must be complied with at all times. Reference must be made to remaining dangers connected with torque measurement technology.



## **Conversions and modifications**

The transducer must not be modified from the design or safety engineering point of view except with our express agreement. Any modification shall exclude all liability on our part for any damage resulting therefrom.

## **Qualified personnel**

The transducer must only be installed and used by qualified personnel, strictly in accordance with the specifications and with safety requirements and regulations. It is also essential to comply with the legal and safety requirements for the application concerned during use. The same applies to the use of accessories.

Qualified personnel means persons entrusted with siting, mounting, starting up and operating the product who possess the appropriate qualifications for their function.

## **Accident prevention**

According to the prevailing accident prevention regulations, once the torque flange has been mounted, a covering agent or cladding has to be fitted as follows:

- The cover or cladding must not be free to rotate.
- The cover or cladding should avoid squeezing or shearing and provide protection against parts that might come loose.
- Covers and cladding must be positioned at a suitable distance or be arranged so that there is no access to any moving parts within.
- Covers and cladding must also be attached if the moving parts of the torque flange are installed outside peoples' movement and operating range.

The only permitted exceptions to the above requirements are if the various parts and assemblies of the machine are already fully protected by the design of the machine or by existing safety precautions.





## **Warranty**

In the case of complaints, a warranty can only be given if the torque flange is returned in the original packaging.

## 2 Markings used

### 2.1 The markings used in this document

Important instructions for your safety are specifically identified. It is essential to follow these instructions in order to prevent accidents and damage to property.

Symbol	Significance
 <b>WARNING</b>	This marking warns of a <i>potentially</i> dangerous situation in which failure to comply with safety requirements <i>can</i> result in death or serious physical injury.
 <b>CAUTION</b>	This marking warns of a <i>potentially</i> dangerous situation in which failure to comply with safety requirements <i>can</i> result in slight or moderate physical injury.
<b>Notice</b>	This marking draws your attention to a situation in which failure to comply with safety requirements <i>can</i> lead to damage to property.
 <b>Important</b>	This marking draws your attention to <i>important</i> information about the product or about handling the product.
 <b>Tip</b>	This marking indicates application tips or other information that is useful to you.
 <b>Information</b>	This marking draws your attention to information about the product or about handling the product.
<i>Emphasis</i> <i>See....</i>	Italics are used to emphasize and highlight text and references to other chapters and external documents.

## 2.2 Symbols on the product

### CE mark



The CE mark enables the manufacturer to guarantee that the product complies with the requirements of the relevant EC directives (the declaration of conformity is available at <http://www.hbm.com/HBMdoc>).

### Label example

Model: T10S2  
FCC ID: 2ADAT-T10S2TOS6  
IC: 12438A-T10S2TOS6  
This device complies with part 15 of the FCC Rules. Operation is subject to the following two conditions: (1) This device may not cause harmful interference, and (2) this device must accept any interference received, including interference that may cause undesired operation.

Label example with Model number, FCC ID and IC number. Location on the stator of the device.

### Statutory waste disposal mark

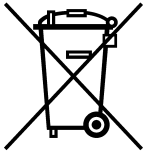

In accordance with national and local environmental protection and material recovery and recycling regulations, old devices that can no longer be used must be disposed of separately and not with normal household garbage.

If you need more information about waste disposal, please contact your local authorities or the dealer from whom you purchased the product.

### 3 Torque flange versions

In the case of option 2 “Electrical configuration”, the T10F torque flange exists in versions KF1, SF1 and SU2. The difference between these versions lies in the electrical inputs and outputs on the stator, the rotors are the same for all the versions of a measuring range. Alternatively, versions SF1 and SU2 can be equipped with a speed measuring system.

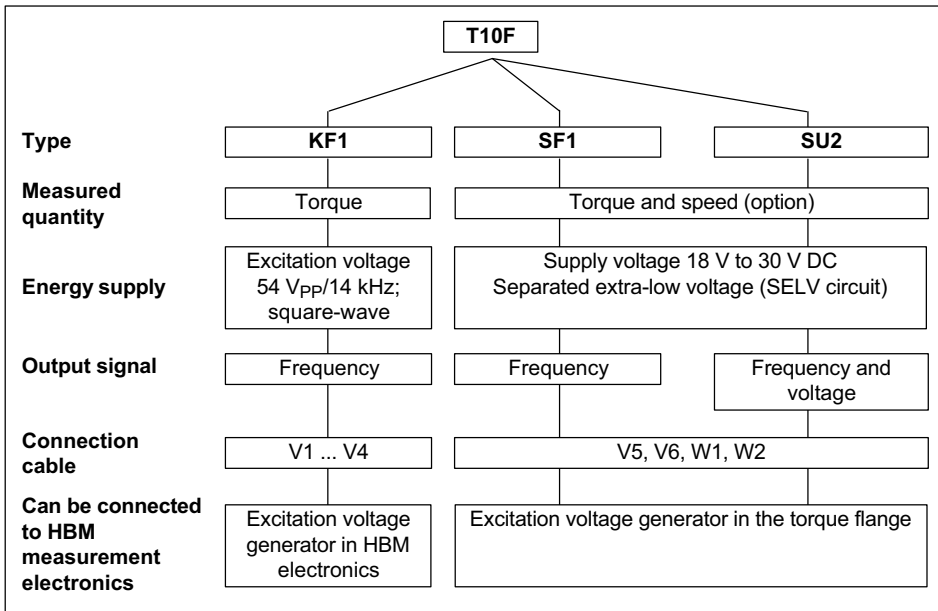

Fig. 3.1 T10F versions

You can find out which version you have from the stator identification plate. The version is specified in the “T10F-...” number there.

Example: T10F-001R-SU2-S-0-V1-Y (see also page 60).

## 4 Application

The T10F torque flanges record static and dynamic torque on stationary or rotating shafts and determine the speed, specifying the direction of rotation. Test beds can be extremely compact because of their extremely short construction. They therefore offer a very wide range of applications.

In addition to conventional test-bench engineering (engine, roll and transmission test benches), new solutions are possible for torque measurements partly integrated in the machines. Here, you benefit in full from the T10F torque flange special characteristics:

- Extremely compact construction with the measurement flange body
- High permissible dynamic load
- High permissible lateral forces and bending moments
- Very high torsional stiffness
- No bearings, no slip rings

Designed to work without bearings, and with contactless excitation voltage and measured value transmission, the measurement flanges are maintenance-free. Thus there are no friction or bearings heating effects.

The torque flanges are supplied for nominal (rated) torques from 50 N·m to 10 kN·m. Depending on the nominal (rated) torque, maximum speeds of up to 15 000 min<sup>-1</sup> are permissible.

T10F torque flanges are reliably protected against electromagnetic interference. They have been tested with regard to EMC according to the relevant European standards, and carry the CE mark.

## 5 Structure and mode of operation

Torque flanges consist of two separate parts: the rotor and the stator. The rotor comprises the measuring body and the signal transmission elements.

Strain gauges (SGs) are mounted on the measuring body. The rotor electronics for transmitting the bridge excitation voltage and the measurement signal are located centrally in the flange. The transmitter coils for contactless transmission of excitation voltage and measurement signal are located on the measuring body's outer circumference. The signals are sent and received by a separable antenna ring. The antenna ring is mounted on a housing that includes the electronic system for voltage adaptation and signal conditioning.

Connectors for the torque signal, the voltage supply and the speed signal (option) are located on the stator. The antenna ring should be mounted more or less concentrically around the rotor (see chapter 6).

In the case of the speed measuring system option, the speed sensor is mounted on the stator, the customer attaches the associated slotted disc on the rotor. The speed measurement works optically with the infrared transmitted light barrier principle.

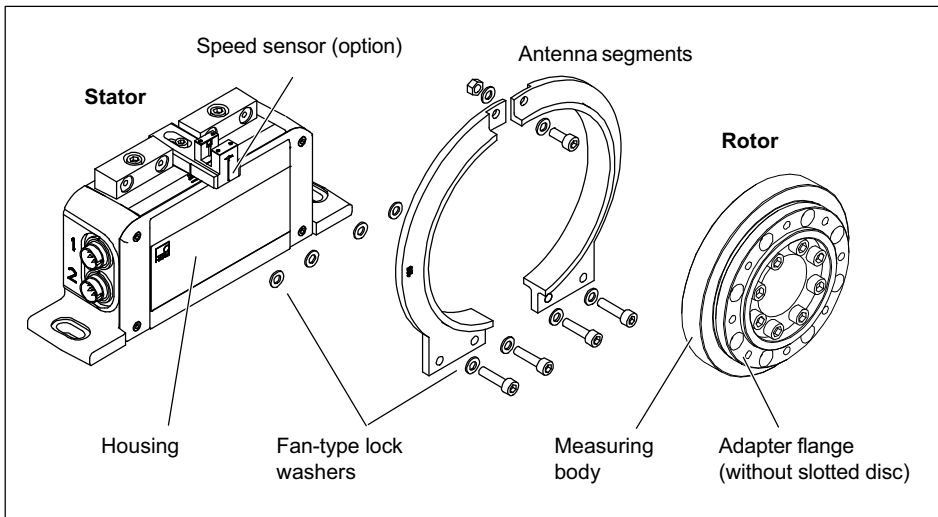

Fig. 5.1 Mechanical structure, exploded view

## 6 Mechanical installation



### WARNING

Handle the torque flange carefully! The transducer could suffer permanent damage from mechanical shock (dropping), chemical effects (e.g. acids, solvents) or thermal effects (hot air, steam).

With alternating loads, you should cement the rotor connection screws into the mating thread with a screw locking device (medium strength) to exclude prestressing loss due to screw slackening.

An appropriate shaft flange enables the T10F torque flanges to be mounted directly. It is also possible to mount a joint shaft or relevant compensating element directly on the rotor (using an intermediate flange when required). Under no circumstances must the permissible limits specified for bending moments, lateral and longitudinal forces be exceeded. Due to the T10F torque flanges' high torsional stiffness, dynamic changes on the shaft train are minimized.



### Important

*The effect on critical bending speeds and natural torsional vibrations must be checked to avoid overloading the measurement flanges due to the resonance stepup.*



### Important

*Even if the unit is installed correctly, the zero point adjustment made at the factory can shift by approx.  $\pm 150$  Hz. If this value is exceeded, we advise you to check the mounting conditions.*

**Important**

For correct operation, comply with the mounting dimensions (see page 58).

## 6.1 Conditions on site

T10F torque flanges are protected to IP54 according to EN 60529. The measuring hubs must be protected against coarse dirt particles, dust, oil, solvents and humidity. During operation, the prevailing safety regulations for the security of personnel must be observed (see *chapter 1 „Safety instructions“, page 6*).

There is wide ranging compensation for the effects of temperature on the output and zero signals of the T10F torque flange (see *chapter 14 „Specifications“, page 62*). This compensation is carried out at static temperatures in extensive furnace processes. This guarantees that the circumstances can be reproduced and the properties of the transducer can be reconstructed at any time.

If there are no static temperature ratios, for example, because of the temperature differences between the measuring body and the flange, the values given in the specifications can be exceeded. So, for accurate measurements, static temperature conditions must then be obtained by cooling or heating depending on the application. As an alternative, check thermal decoupling by means of heat radiating elements such as multi-disc couplings.

## 6.2 Installation orientation

The measurement flange can be mounted in any position. With clockwise torque, the output frequency is 10 kHz to 15 kHz. With HBM amplifiers or with the “voltage output” option, a positive output signal (0 V ... +10 V) is present.

In the case of the speed measuring system, an arrow is attached to the head of the sensor to clearly define the direction of rotation. If the measurement flange moves in the direction of the arrow, connected HBM measuring amplifiers deliver a positive output signal (0 V ... +10 V).



### 6.3 Installation options

In principle, there are two possibilities for torque flange mounting: with the antenna ring complete or dismantled. We recommend mounting as described in *chapter 6.3.1. "Installation without dismantling the antenna ring"* If installation in accordance with *chapter 6.3.1* is not possible, (e.g. in the case of subsequent stator replacement or mounting with a speed measuring system), you will have to dismantle the antenna ring. It is essential in this case to comply with the notes on assembling the antenna segments (see *chapter 6.5 "Mounting the stator" on page 24 and chapter 6.7 "Fitting the slotted disc (speed measuring system)" on page 29*).

### 6.3.1 Installation without dismantling the antenna ring

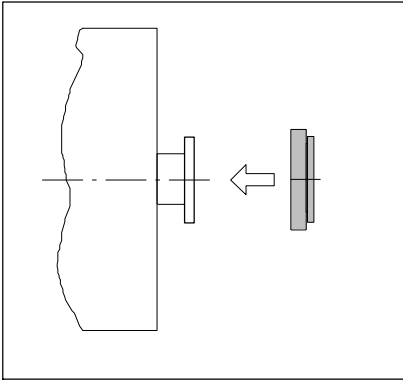

1. Install rotor

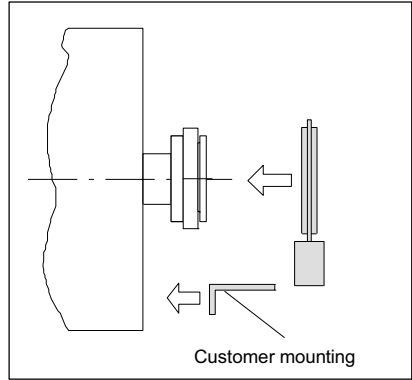

2. Install stator

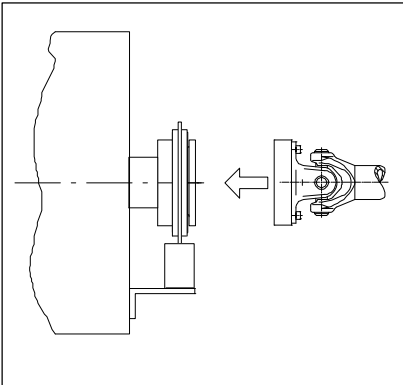

3. Finish installation of shaft train

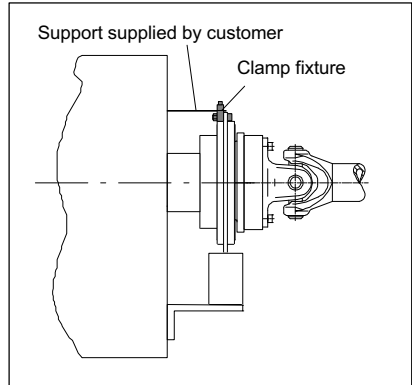

4. Mount the clamp fixture where required

### 6.3.2 Installation with subsequent stator mounting

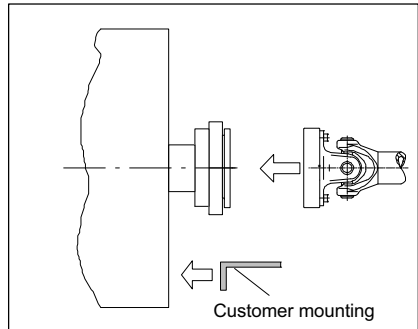
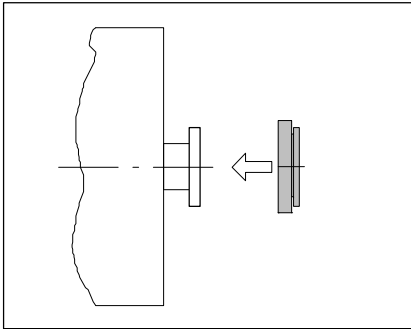

2. Install shaft train

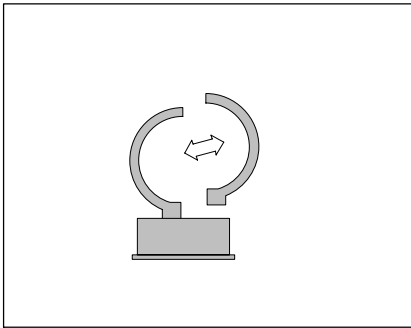

3. Remove one antenna segment

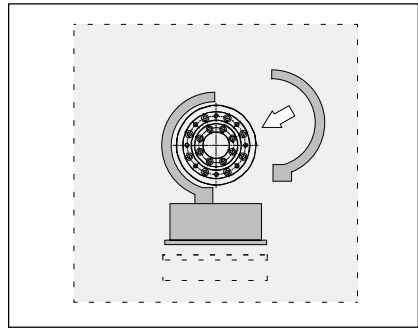

4. Install antenna segment around shaft train

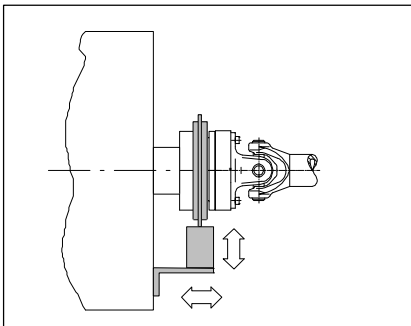

5. Align stator and finish installation

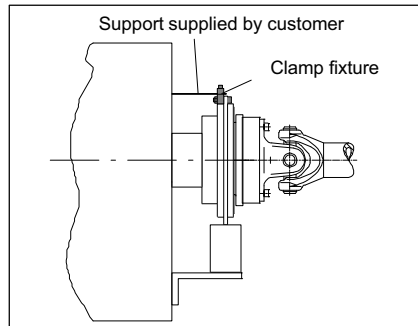

6. Mount the clamp fixture where required

### 6.3.3 Installation example with couplings

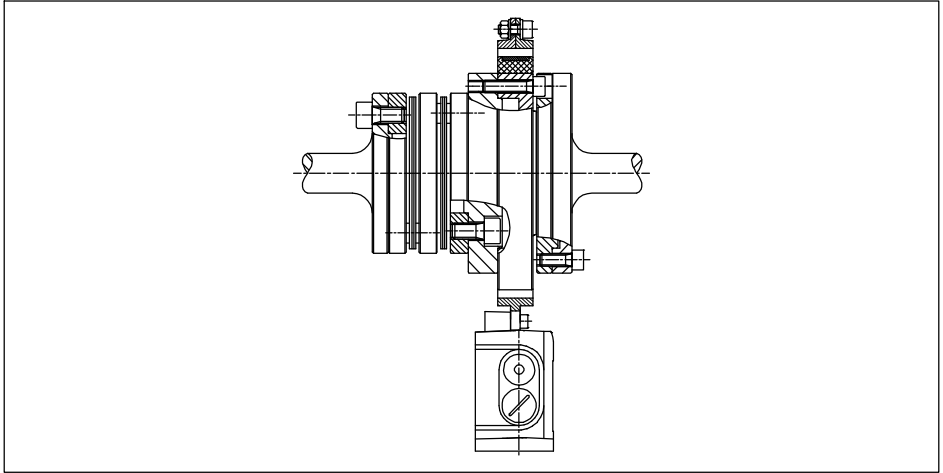

Fig. 6.1 Installation example with coupling

### 6.3.4 Installation example with joint shaft

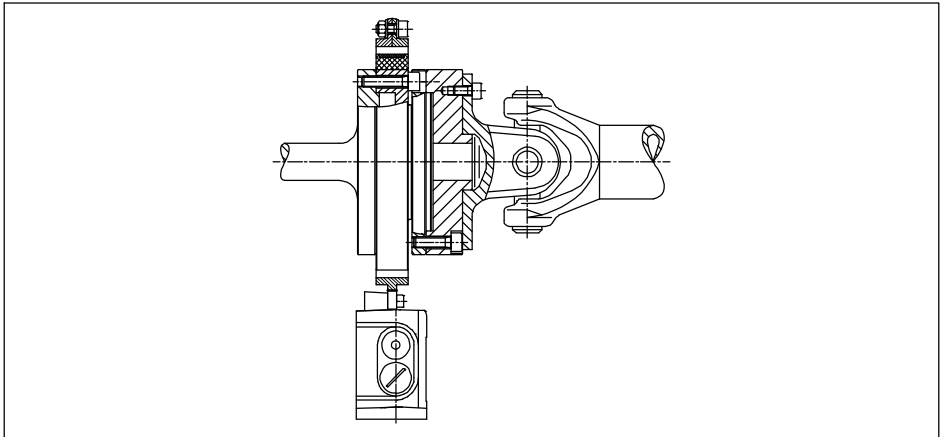

Fig. 6.2 Installation example with joint shaft

## 6.4 Mounting the rotor



### Important

*For correct operation, comply with the mounting dimensions (particularly the area free of metal, see page 58).*

Additional installation notes for the speed measuring system can be found in *chapter 6.7, page 29*.



### Important

*Usually the rotor identification plate is no longer visible after installation. This is why we include with the rotor additional stickers with the important ratings, which you can attach to the stator or any other relevant test-bench components. You can then refer to them whenever there is anything you wish to know, such as the calibration signal.*

1. Prior to installation, clean the plane surfaces of the measurement flanges and counter flanges. For safe torque transfer, the surfaces must be clean and free from grease. Use a piece of cloth or paper soaked in solvent. When cleaning, make sure that you do not damage the transmitter coils.

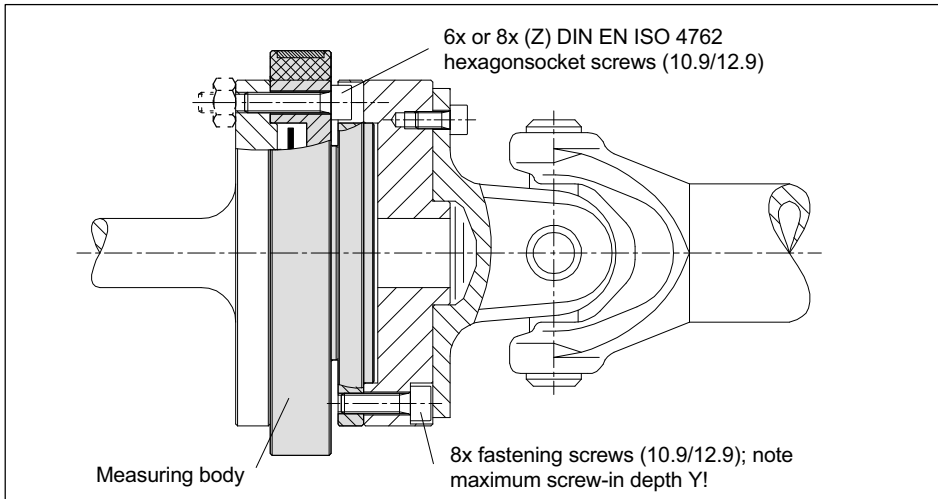

Fig. 6.3 Screwed rotor joint

- For the bolted rotor connection, use eight *DIN EN ISO 4762 property class 10.9 hexagon socket screws (measuring range 10 kN·m: 12.9)* of a suitable length (dependent on the connection geometry, see Fig. 6.4).

We recommend, particularly for 50 N·, 100 N·m and 200 N·m, fillisterhead screws DIN EN ISO 4762..., blackened, smoothheaded, oiled,  $m_{tot}$  0.125 permitted size and shape variance in accordance with DIN ISO 4759, Part 1, product class A.



## WARNING

The screw heads (Z), see Fig. 6.4, must not touch the adapter flange.

With alternating load: Use a screw locking device (e.g. LOCTITE no. 242) to glue the screws into the counter thread to exclude prestressing loss due to screw slackening.

- Before the final tightening of the screws, rotate the torque flange on the centering device until all screw heads are positioned approximately centrally

in the through-holes of the connection element. The screw heads must not touch the walls of the through-holes in the adapter flange!

4. Fasten all screws with the specified tightening torque (see Fig. 6.4).
5. For further mounting of the shaft train, there are eight tapped holes on the adapter flange. Also use screws of property class 10.9 (or 12.9) and fasten with the torque specified in Fig. 6.4.



### Important

*With alternating loads, use a screw locking device to cement the connecting screws into place! Guard against contamination from varnish fragments. The maximum screw-in depth as per Fig. 6.4 must be complied with! Otherwise, significant measurement errors may result from torque shunts or the transducer may be damaged.*

Nominal (rated) torque (N·m)	Fastening screws (Z) <sup>1)</sup>	Fastening screws Property class	Max. screw-in depth (Y) of screws in the adapter flange (mm)	Prescribed tightening torque (N·m)
50	M6	10.9	7.5 <sup>2)</sup>	14
100				
200	M8		11	34
500	M12		18	115
1 k	M12		18	115
2 k	M14		18	185
3 k	M14		26	185
5 k	M18		33.5	400
10 k	M18	12.9 <sup>3)</sup>	33.5	470

1) DIN EN ISO 4762; black/oiled/ $t_{tot} = 0.125$

2) 14 mm for speed module option; use 6 mm longer screws because of the intermediate flange.

3) If property class 12.9 screws are not available, class 10.9 screws can also be used (tightening torque 400 N·m). The permissible limit torque then reduces to 120% related to  $M_{nom}$ .

Fig. 6.4 Fastening screws

## 6.5 Mounting the stator

On delivery, the stator has already been installed and is ready for operation. The antenna segments can be separated from the stator, for example, for maintenance or to facilitate stator mounting. To stop you modifying the center alignment of the segment rings opposite the base of the stator, we recommend that you separate only one antenna segment from the stator.

If your application does not require the stator to be dismantled, proceed as described in points 2., 6., 7. and 8.

### Version with speed measuring system

As the speed sensor includes the slotted disc, it is not possible to move the stator axially over the pre-assembled rotor (exception: Measuring ranges 50 N·m, 100 N·m and 200 N·m).

In this case, you should also comply with *chapter 6.7*

*“Fitting the slotted disc (speed measuring system)”, page 29.*



### Important

*Check the screw connections of the antenna segments (see Fig. 6.5) both after initial installation and then at regular intervals for correct fit and tighten them if necessary.*



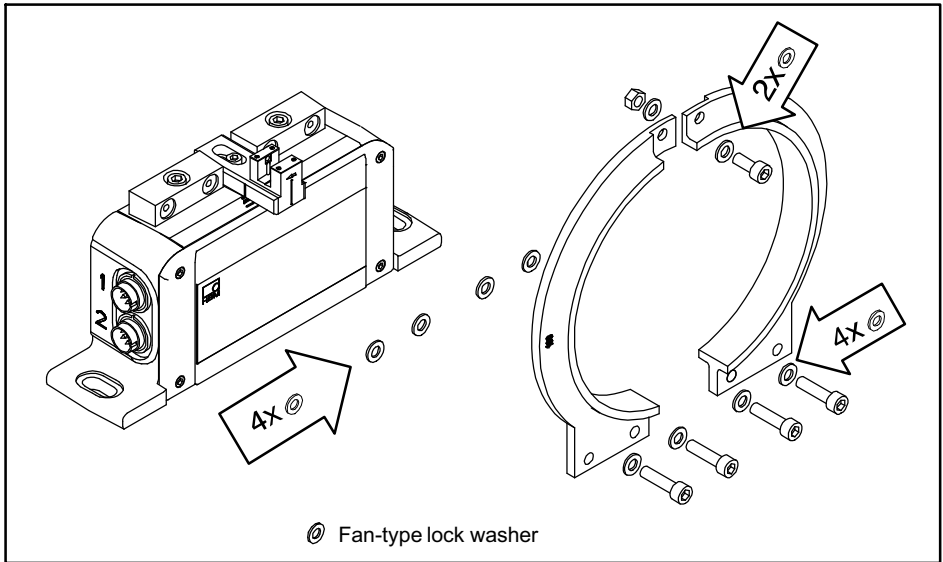
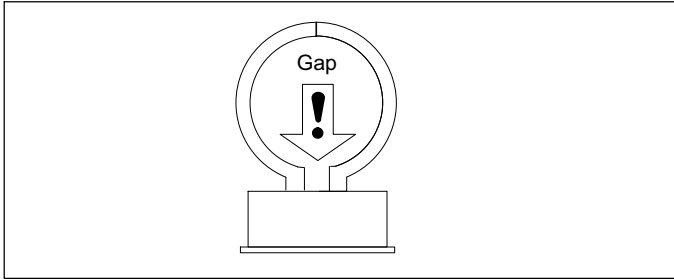

Fig. 6.5 Screw fittings of the antenna segments

1. Loosen and remove the screw fittings (M5) on one antenna segment. Make sure that the fan-type lock washers are not lost!
2. Use an appropriate base plate to install the stator housing in the shaft train so that there is sufficient possibility for horizontal and vertical adjustments. Do not fully tighten the screws yet.
3. Now reinstall the antenna segment removed under point 1. on the stator with two hexagon-socket screws and the fan-type lock washers. Make sure that none of the fan-type lock washers necessary for a defined contact resistance are missing (see Fig. 6.5)! Do not yet tighten the screws.
4. Install the two antenna segments' upper connecting screw so that the antenna ring is closed. Also pay attention to the fan-type lock washers.
5. Now fasten all the bolted antenna-segment connections with a tightening torque of 5 N·m.
6. Align the antenna and rotor so that the antenna encloses the rotor coaxially. Please comply with the permissible alignment tolerances stated in the specifications.

7. Now fully tighten the bolted stator housing connection.
8. Make sure that the gap in the lower antenna segment area is free of electrically conductive foreign bodies.



**Important**

*To guarantee that they function perfectly, the fan-type lock washers (A5, 3-FST DIN 6798 ZN/galvanized) must be replaced after the bolted antenna connection has been loosened three times.*

## 6.6 Installing the clamp fixture

Depending on the operating conditions, oscillations may be induced in the antenna ring. This effect is dependent on:

- the speed
- the antenna diameter (depends in turn on the measuring range)
- the design of the machine base

To avoid vibrations, a clamp fixture is enclosed with the torque flange enabling the antenna ring to be supported.

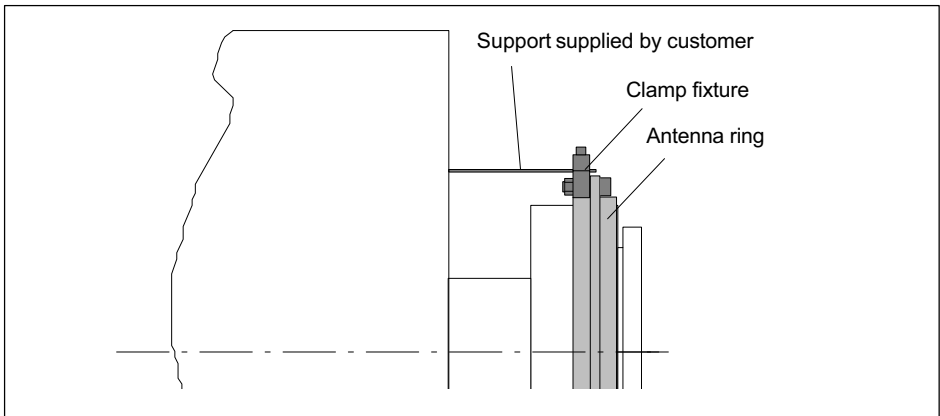

Fig. 6.6 Supporting the antenna ring

### Mounting sequence

1. Loosen and remove the upper antenna segment screw fitting.
2. Fasten the clamp fixture with the enclosed screw fitting as shown in *Fig. 6.7*. It is essential to use the new fan-type locking washers!
3. Clamp a suitable support element (we recommend a threaded rod  $\varnothing$  3...6mm) between the upper and lower parts of the clamp fixture and tighten the clamping screws.

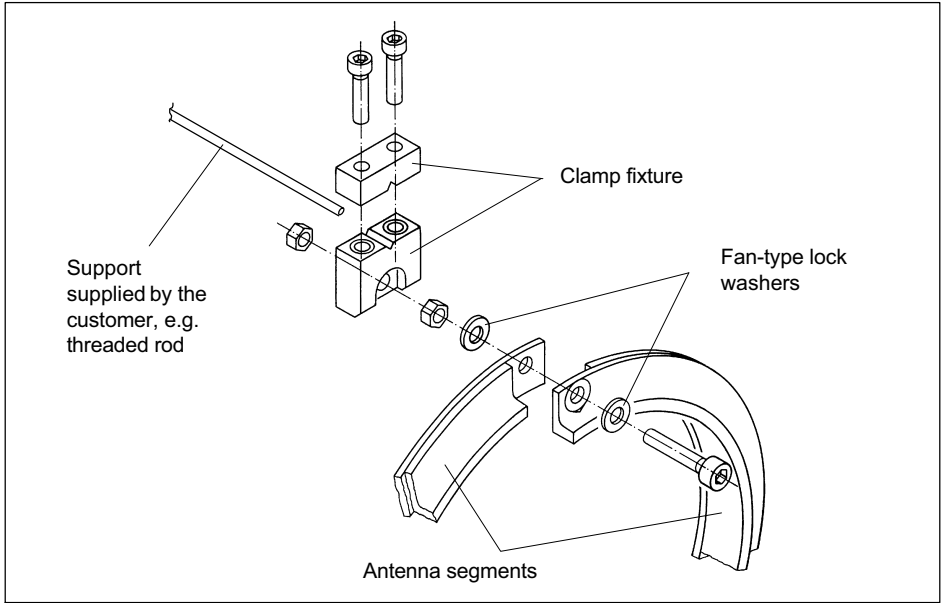

Fig. 6.7 Installing the clamp fixture



**Important**

*Use, e.g. plastic as the material. Do not use metallic material as this can affect the function of the antenna (signal transmission).*

## 6.7 Fitting the slotted disc (speed measuring system)

To prevent damage to the optical speed measuring systems' slotted disc during transportation, it is not mounted on the rotor. Before installing the rotor in the shaft train, you must attach it to the adapter flange (or intermediate flange). The associated speed sensor is already mounted on the stator.

The requisite screws, a suitable screwdriver and the screw locking device are included in the list of components supplied.

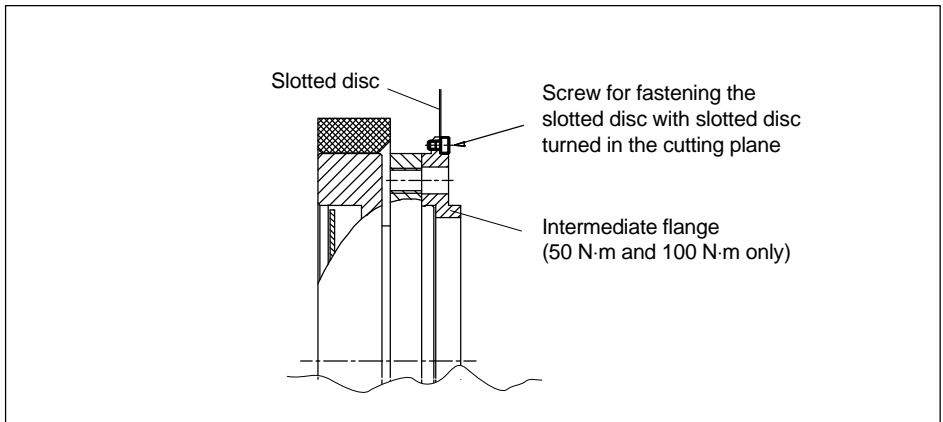

Fig. 6.8 Installing the slotted disc



### Important

*At all stages of the mounting operation, be careful not to damage the slotted disc!*

### Mounting sequence

1. Push the slotted disc onto the adapter flange (or additional flange) and align the screw holes.
2. Apply some screw locking device to the screw thread and tighten the screws (tightening torque <math>< 15 \text{ N}\cdot\text{cm}</math>).

## 6.8 Aligning the stator (speed measuring system)

The stator can be mounted in any position (for example, “upside down” installation is possible). For perfect measuring mode, the slotted disc of the speed measuring system must rotate at a defined position in the sensor pickup.

### Axial alignment

There is a mark (orientation line) in the sensor pickup for axial alignment (orientation line). When installed, the slotted disc should be exactly above this orientation line. Divergence of up to  $\pm 2$  mm is permissible in measuring mode (total of static and dynamic shift).

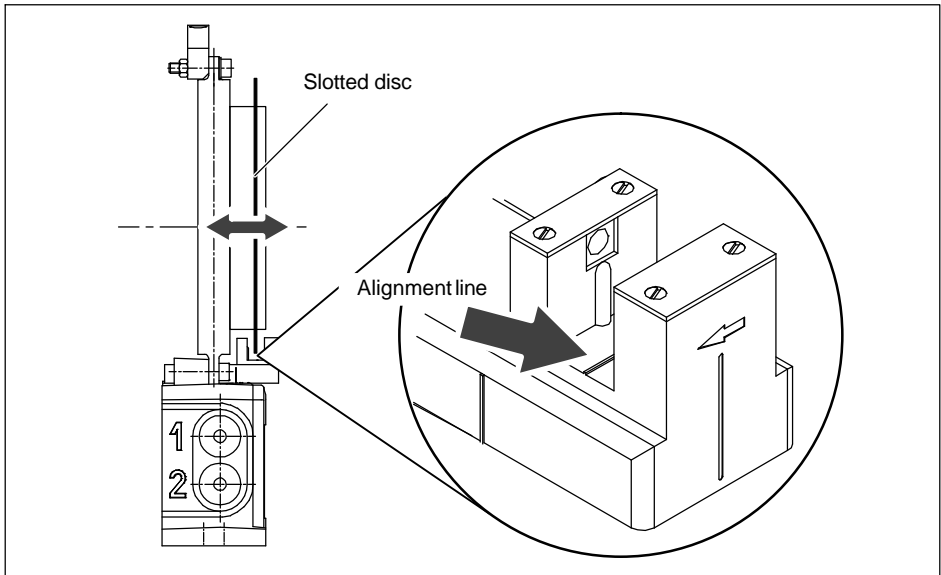

Fig. 6.9 Position of the slotted disc in the speed sensor



### Important

To attach the stator, we recommend the use of M6 screws with plain washers (width of oblong hole, 9 mm). This size of screw guarantees the necessary travel for alignment.

### Radial alignment

The rotor axis and the optical axis of the speed sensor must be along a line at right angles to the stator platform. A conical machined angle (or a colored mark) in the center of the adapter flange and a vertical marker line on the sensor head serve as aids to orientation.

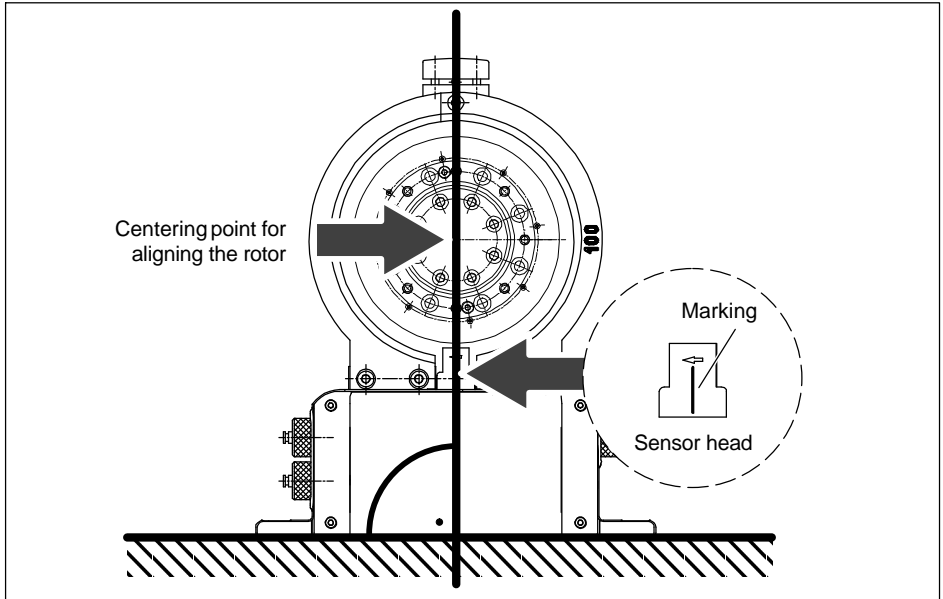

Fig. 6.10 Alignment marks on rotor and stator

## 7 Electrical connection

### 7.1 General information

To make the electrical connection between the torque transducer and the amplifier, we recommend using shielded, low-capacitance measurement cables from HBM.

With cable extensions, make sure that there is a proper connection with minimum contact resistance and good insulation. All plug connections or swivel nuts must be fully tightened.

Do not route the measurement cables parallel to power lines and control circuits. If this cannot be avoided (in cable pits, for example), maintain a minimum distance of 50 cm and also draw the measurement cable into a steel tube.

Avoid transformers, motors, contactors, thyristor controls and similar stray-field sources.



#### Important

*Transducer connection cables from HBM with attached connectors are identified in accordance with their intended purpose (Md or n). When cables are shortened, inserted into cable ducts or installed in control cabinets, this identification can get lost or become concealed. If this is the case, it is essential for the cables to be re-labeled!*

#### 7.1.1 FCC and IC compliant installation for US and Canada installation only

##### Use of EMI suppressor

To suppress high frequencies a EMI suppressor on the power cable has to be used. Use at least 3 loops of the cable.

Fastening must be done in an area not subject to mechanical loads (i.e. no unwanted vibrations, etc.) using cable ties fit for the specific application.



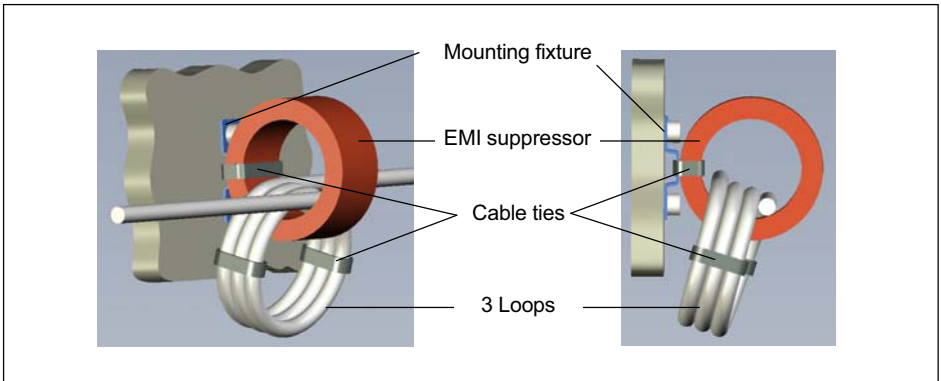

Fig. 7.1 Installation example EMI suppressor



**Information**

Consider longer cable of approximately 40 cm due to the installation of the EMI suppressor.

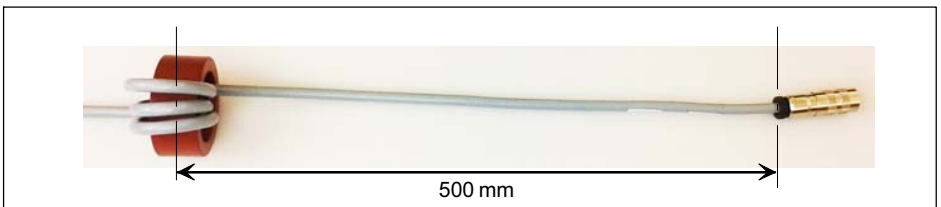

Fig. 7.2 Max. distance of EMI suppressor to connector

If the EMI suppressor has to be removed for any purpose (e.g. for maintenance), it must be replaced on the cable. Use only EMI suppressor of the correct type.

Type: Vitroperm R

Model No.: T60006-22063W517

Size: external diameter x internal diameter x height = 63 x 50 x 25

The installation requires a EMI suppressor to be added to the cable. Additional fixture should be used to prevent stress on the connector due to extra weight of the cable.



### Important

*The use of the EMI suppressor on the power cable (plug 1 or plug 3) is mandatory to ensure compliance with FCC regulations.*

## 7.2 Shielding design

The cable shield is connected in accordance with the Greenline concept. This encloses the measurement system (without the rotor) in a Faraday cage. It is important that the shield is laid flat on the housing ground at both ends of the cable. Any electromagnetic interference active here does not affect the measurement signal. Special electronic coding methods are used to protect the transmission path and the rotor from electromagnetic interference.

In the case of interference due to potential differences (compensating currents), operating voltage zero and housing ground must be disconnected on the amplifier and a potential equalization line established between the stator housing and the amplifier housing (copper conductor, 10 mm<sup>2</sup> wire cross-section).

If potential differences arise between the rotor and the stator on the machine, perhaps due to unchecked leakage, and this causes interference, it can usually be overcome by connecting the rotor directly to ground, for instance by a wire loop. The stator should be fully grounded in the same way.

### 7.3 Option 2, code KF1

The stator housing has a 7-pin (Binder 723) device connector, to which you link the connection cable for voltage supply and torque signal.

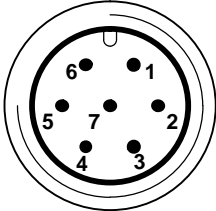
	Conn. Binder Pin	Assignment	Wire color	MS3106 conn. Pin
 <p data-bbox="165 459 288 483"><b>Binder 723</b></p> <p data-bbox="180 751 277 775">Top view</p>	1	Supply voltage zero	wh	A
	2	No function	bk	B
	3	Pre-amplifier supply voltage (+15 V)	bu	C
	4	Torque measurement signal (12 V <sub>PP</sub> ; 5...15 kHz)	rd	D
	5	No function		
	6	Rotor excitation voltage (54 V/80 V <sub>PP</sub> ; approx. 15 kHz)	gn	F
	7	Rotor excitation voltage (0 V)	gy	G
		Shielding connected to housing ground		

#### 7.3.1 Adaptation to the cable length

The transmission method between the rotor and the stator determines the function of the torque flange, which is dependent on:

- the installation situation (for example, covering, area free of metal parts)
- the length of the cable
- the tolerances of the excitation voltage supply

To allow for adaptation to various conditions, there are three switches in the stator housing, which can be accessed by removing the stator cover.

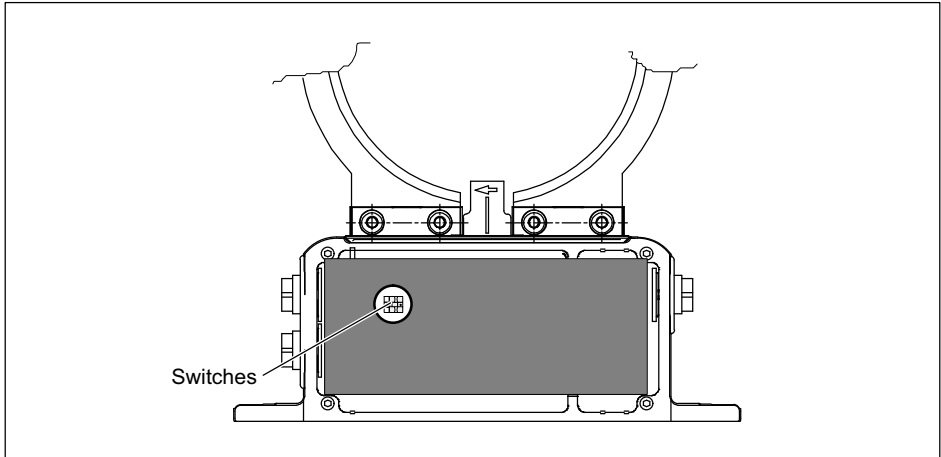





Fig. 7.3 Switches in the stator housing

Switch position		Example applications
1		a) Older amplifiers b) For when the calibration signal is unintentionally initiated with very short cables
2		Normal position (factory setting)
3		For cable lengths in excess of approx. 20 m

Please ensure that after changing to switch position 3, the calibration signal is not initiated.

**Possible faults and their elimination:**

*Fault:* No signal at the output, amplifier indicates overflow.

*Cause:* Too little power, T10F disconnects.

*Remedy:* Switch position 3.

*Fault:* The calibration signal has been triggered by mistake.

*Remedy:* Switch position 1.





## 7.4 Option 2, code SF1/SU2

On the stator housing, there are two 7-pin device connectors (Binder 723) and in the case of the speed module option, there is also an 8-pin device connector, assigned in accordance with the selected option.

The supply voltage and the calibration signal of connectors 1 and 3 are direct-coupled via multifuses (automatically resetting fuses).

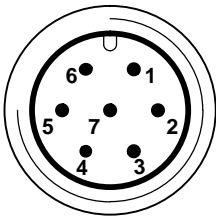
### Assignment for connector 1

Voltage supply and frequency output signal.

	Binder conn. Pin	Assignment	Wire color	Sub-D conn. Pin
<p data-bbox="161 683 284 707"><b>Binder 723</b></p>  <p data-bbox="176 978 273 1002">Top view</p>	1	Torque measurement signal (frequency output; 5 V <sup>1</sup> ; 0 V) 	wh	13
	2	Supply voltage 0 V; 	bk	5
	3	Supply voltage 18 V ... 30 V	bu	6
	4	Torque measurement signal (frequency output; 5 V <sup>1/12</sup> V)	rd	12
	5	Measurement signal 0 V;  symmetrical	gy	8
	6	Calibration signal trigger 5 V - 30 V	gn	14
	7	Calibration signal 0 V; 	gy	8
		Shielding connected to housing ground		

1) Factory setting; complementary signals RS-422





**Important**

The torque flanges of option 3, code SF1/SU2 are only intended for operation with a DC supply voltage. They must not be connected to older HBM amplifiers with square-wave excitation. This could lead to the destruction of the connection board resistances or other errors in the measuring amplifiers (the torque flange, on the other hand, is protected and once the proper connections have been re-established, is ready for operation again).

**Assignment connector 2**

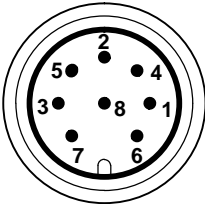
Speed measuring system





 <p>Binder 723</p> <p>Top view</p>	Conn. Binder Pin	Assignment	Wire color	Sub-D conn. Pin
	1	Speed measurement signal (pulse string, 5 V <sup>1</sup> ; 0°)	rd	12
	2	No function	-	-
	3	Speed measurement signal (pulse string, 5 V <sup>1</sup> ; phase-shifted by 90°) <sup>2</sup>	gy	15
	4	No function	-	-
	5	No function	-	-
	6	Speed measurement signal (pulse string, 5 V <sup>1</sup> ; 0°)	wh	13
	7	Speed measurement signal (pulse string, 5 V <sup>1</sup> ; phase-shifted by 90°) <sup>2</sup>	gn	14
	8	Supply voltage zero 	bk	8
	Shielding connected to housing ground			

1) RS-422 complementary signals

2) When switching to double frequency, static direction of rotation signal.

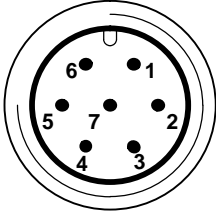
### Assignment connector 3

Voltage supply and voltage output signal.

Binder 723  Top view	Conn. Binder Pin	Assignment
	1	Torque measurement signal (voltage output; 0 V  )
	2	Supply voltage 0 V; 
	3	Supply voltage 18 V ... 30 V DC
	4	Torque measurement signal (voltage output; $\pm 10$ V)
	5	No function
	6	Calibration signal trigger 5 V - 30 V
	7	Calibration signal 0 V; 
	Shielding connected to housing ground	

## 7.5 Supply voltage

The transducer must be operated with a separated extra-low voltage (18...30 V DC supply voltage), which usually supplies one or more consumers within a test bench.

Should the equipment be operated on a DC voltage network<sup>1)</sup>, additional precautions must be taken to discharge excess voltages.

The notes in this chapter relate to the standalone operation of the T10F without HBM system solutions.

The supply voltage is electrically isolated from signal outputs and calibration signal-inputs. Connect a separated extra-low voltage of 18 V ... 30 V to pin 3 (+) and pin 2 () of connector 1 or 3. We recommend that you use HBM cable KAB 8/00-2/2/2 and relevant Binder sockets, that at nominal (rated)

<sup>1)</sup> Distribution system for electrical energy with greater physical expansion (over several test benches, for example) that may possibly also supply consumers with high nominal (rated) currents.

voltage (24 V) can be up to 50 m long and in the nominal (rated) voltage range, 20m long (see chapter 13 “Order numbers, accessories”, page 60).

If the permissible cable length is exceeded, you can feed the supply voltage in parallel over two connection cables (connectors 1 and 3). This enables you to double the permissible length. Alternatively an on-site power pack should be installed.

If you feed the supply voltage through an unshielded cable, the cable must be twisted (interference suppression). We also recommend that a ferrite element should be located close to the connector plug on the cable, and that the stator should be grounded.



### **Important**

*At the instant of power-up, a current of up to 2 A may flow, which could switch off power packs with electronic current limiters.*



## 8 Calibration

The T10F torque flange delivers an electrical calibration signal that can be switched at the amplifier end for measurement chains with HBM components. The measurement flange generates a calibration signal of about 50 % of the nominal (rated) torque. The precise value is specified on the type plate. Adjust the amplifier output signal to the calibration signal supplied by the connected torque flange to adapt the amplifier to the measurement flange.

To obtain stable conditions, the calibration signal should only be activated once the transducer has been warming up for 15 minutes.

The framework conditions for comparability (e.g. installation situation) must be implemented in order to reproduce the measured values in the test certificate.



### Important

*The measurement flange should not be under load when the calibration signal is being measured, since the calibration signal is mixed additively.*



### Important

*To maintain measurement accuracy, the calibration signal should be connected for no more than 5 minutes. A similar period is then needed as a cooling phase before triggering the calibration signal again.*

### 8.1 Calibration option 2, code KF1

Increasing the excitation voltage from  $54V_{PP}$  to  $80V_{PP}$  (pins 6 and 7, connector 1), triggers the calibration signal.

### 8.2 Calibration option 2, code SF1/SU2

Applying a separated extra-low voltage of 5 V to pin 6 (+) and 7 () on connector 1 or 3 triggers the calibration signal.

The nominal (rated) voltage for triggering the calibration signal is 5 V (triggered when  $U > 2.7$  V). The trigger voltage is electrically isolated from the supply voltage and the measurement voltage. The maximum permissible voltage is 30 V. When voltages are less than 0.7 V, the measurement flange is in measuring mode. Current consumption at nominal (rated) voltage is approx. 2mA and at maximum voltage is approx. 22mA.



### **Important**

*In the case of HBM system solutions, the measuring amplifier triggers the calibration signal.*

## 9 Settings



### Important

You will find a table containing all the relevant switch positions on the back of the stator cover. Changes to the factory settings should be noted or entered here using a waterproof felt-tip pen.

Einstellungen / Settings OPTION 5								
Impulse/Umdrehung Pulses/revolution	360	180	90	60	30	15	720	
$M_{nom}$ 100 N·m to 3 kN·m								WERKSEINSTELLUNG Factory settings Eigene Einstellungen Customized settings  ON DIP 1 2 3 4 5 6
$M_{nom}$ 5 kN·m to 10 kN·m								
 Hysterese Hysteresis	 ein / on <input checked="" type="checkbox"/>			 aus / off <input type="checkbox"/>				
Frequenz Ausgangsspannung Frequency output voltage	 CH1				 CH2 <input checked="" type="checkbox"/>			

Fig. 9.1 Sticker with switch positions; optical speed measuring system

## 9.1 Torque output signal, code KF1

The factory setting for the frequency output voltage is 12 V (asymmetrical). The frequency signal is on pin 4 opposite pin 1. It is not possible to change over.

## 9.2 Torque output signal, code SF1/SU2

The factory setting for the frequency output voltage is 5 V (symmetrical, complementary RS-422 signals). The frequency signal is on pin 4 opposite pin 1. You can change the output voltage to 12 V (asymmetrical). To do this, change switches S1 and S2 to position 1 (and pin 1 → ).

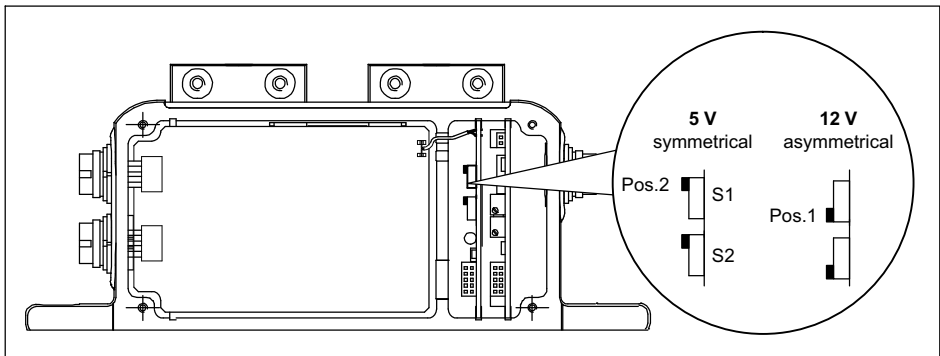

Fig. 9.2 Switch for changing the frequency output voltage

## 9.3 Setting up the zero point

In the case of the torque flange with the voltage output option (SU2), you can access two potentiometers by removing the stator cover. You can use the zero point potentiometer to correct zero point deviations caused by the installation. The balancing range is a minimum of  $\pm 400$  mV at nominal (rated) gain. The end point potentiometer is used for compensation at the factory and is capped with varnish so that it cannot be turned unintentionally.



### Important

*Turning the end point potentiometer changes the factory calibration of the voltage output.*

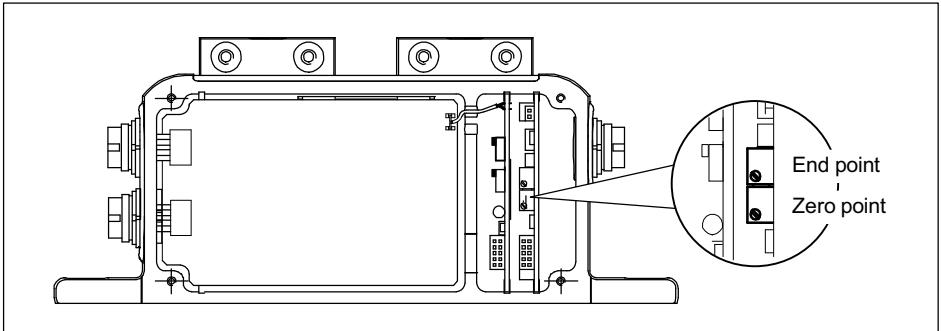

*Fig. 9.3 Setting the voltage output zero point*

## 9.4 Functional testing

### 9.4.1 Power transmission

If you suspect that the transmission system is not working properly, you can remove the stator cover and test for correct functioning. If the LED is on, the rotor and stator are properly aligned and there is no interference with the transmission of measurement signals. When the calibration signal is triggered, the LED shines more brightly.

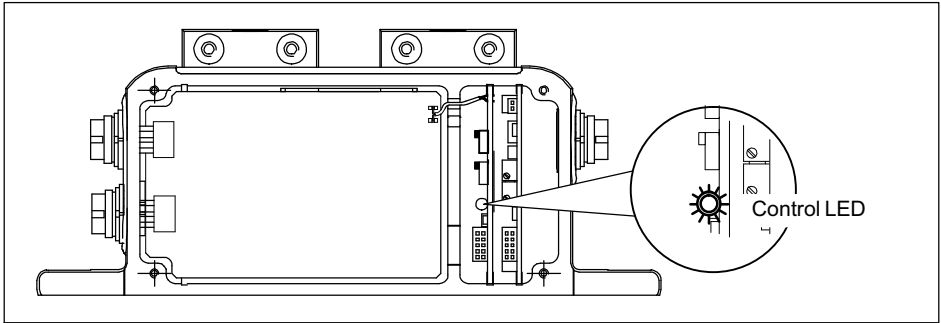

Fig. 9.4 Power transmission function test

### 9.4.2 Aligning the speed module

When required, you can test the correct functioning of the speed measuring system.

1. Remove the cover of the stator housing.
2. Turn the rotor by at least  $2 \text{ min}^{-1}$ .

If both the control LEDs come on while you are turning the rotor, the speed measuring system is properly aligned and fully operational.

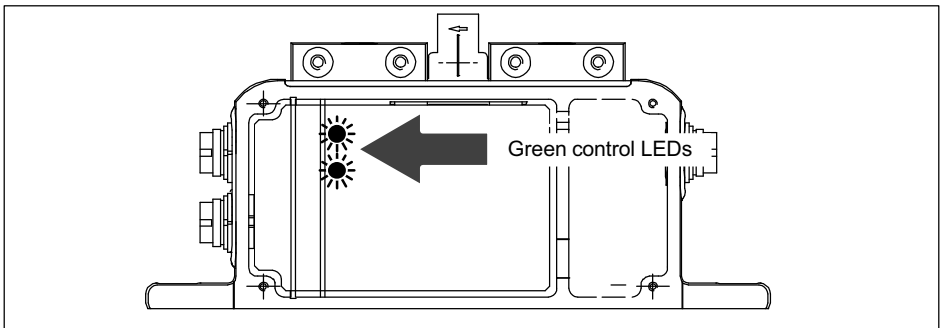

Fig. 9.5 Control LEDs of the speed measuring system



### Important

When closing the cover of the stator housing, make sure that the internal connection cables are positioned in the grooves provided and are not trapped.

## 9.5 Setting the pulse count

The number of pulses per revolution of the rotor in the speed module option can be adjusted by means of DIP switches S1...S4.

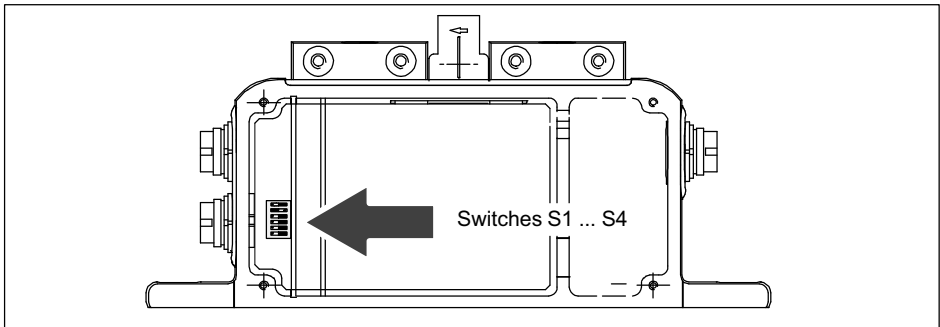

Fig. 9.6 Switches for setting the pulse count

### Setting the pulse count

1. Remove the stator cover.
2. Use switches S1 ... S4 as per Tab. 7.1 to set the required pulse count.

Pulses/ revolution1)	360	180	90	60	30	15	720
Rated torque 50 N·m...1 kN·m							
Rated torque 2 N·m...10 kN·m							

1) Factory setting with option 4

Fig. 9.7 Switch settings for the pulse count

(■  $\triangle$  switch lever)

## 9.6 Vibration suppression (hysteresis)

Low rotation speeds and higher relative vibrations between the rotor and the stator can cause disturbance signals that reverse the direction of rotation. Electronic suppression (hysteresis) to eliminate these disturbances is connected at the factory. Disturbances caused by the radial stator vibration amplitude and by the torsional vibration of the rotor are suppressed.

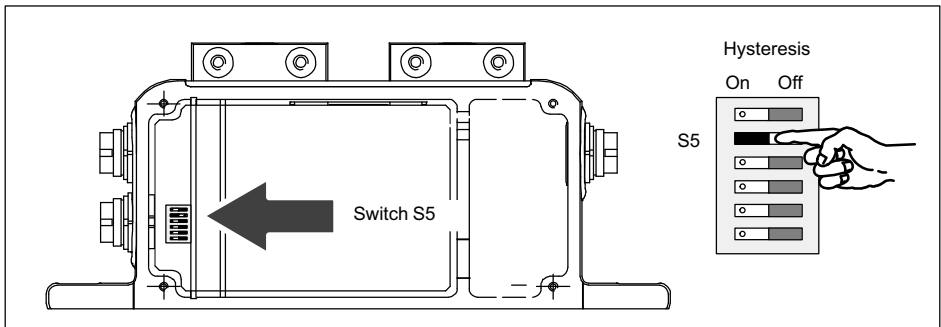

Fig. 9.8 Switch for switching off hysteresis



## 9.7 Form of speed output signal

In the factory setting, two 90° phase-offset speed signals (5 V symmetrical, complementary RS-422 signals) are available at the speed output (connector 2). You can double the pulse count set in each case by moving switch S6 to the "On" position. Pin 3 then outputs the direction of rotation as a static direction of rotation signal (pin 3 = +5 V, pin 7 = 0 V compared to pin 8), if the shaft turns in the direction of the arrow. At a speed of 0 min<sup>-1</sup>, the direction of rotation signal has the last measured value.

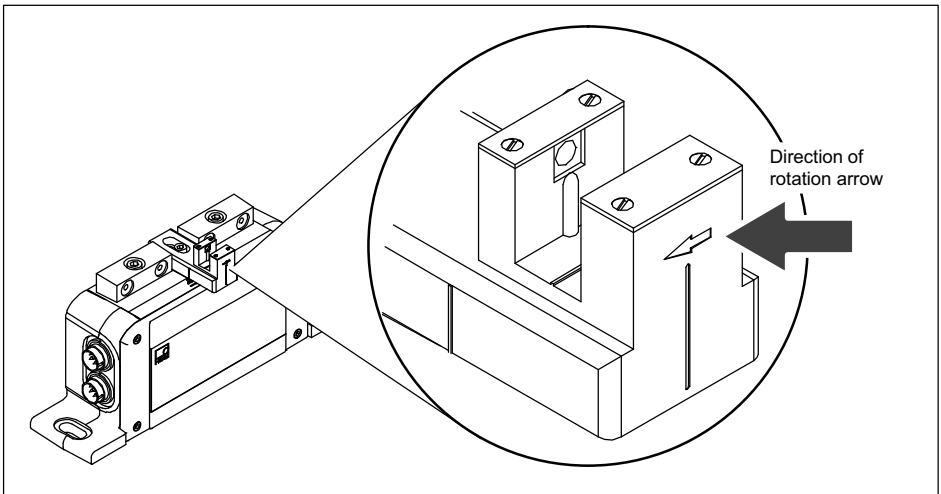

Fig. 9.9 Direction of rotation arrow on the head of the sensor

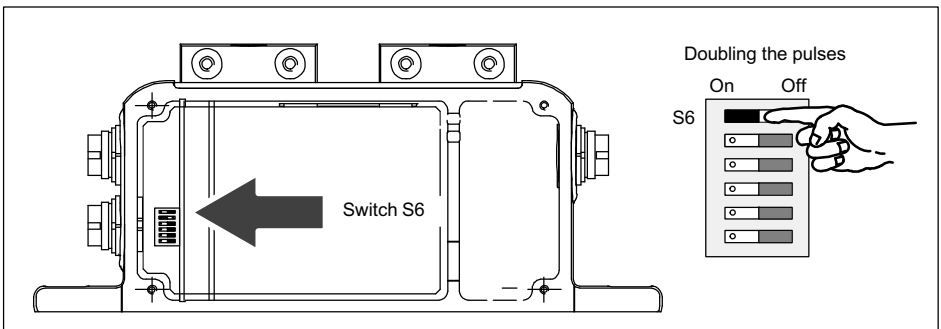
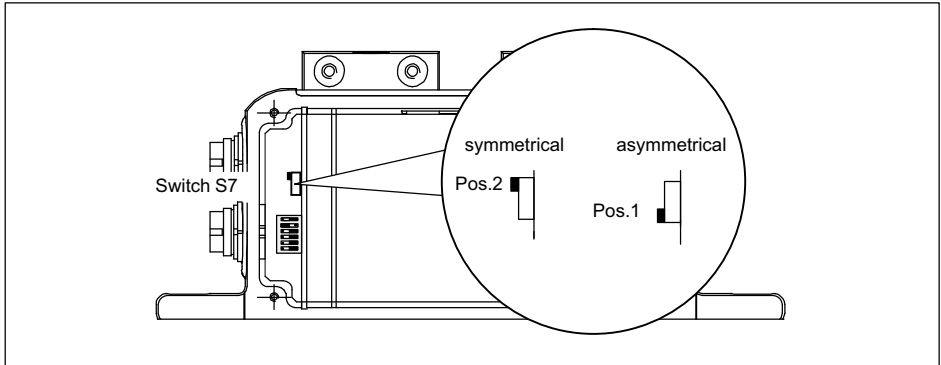

Fig. 9.10 Switch for doubling the pulses

## 9.8 Type of speed output signal

You can use switch S7 to change the symmetrical 5 V output signal (factory setting) to an asymmetrical signal of 0 V ... 5 V.



*Fig. 9.11 Switch S7; symmetrical/asymmetrical output signal*

## 10 Loading capacity

Nominal torque can be exceeded statically up to the limit torque. If the nominal torque is exceeded, additional irregular loading is not permissible. This includes longitudinal forces, lateral forces and bending moments. Limit values can be found in *chapter 14 "Specifications", on page 62.*

### 10.1 Measuring dynamic torque

The torque flanges can be used to measure static and dynamic torques. The following rule applies to the measurement of dynamic torque:

- The T10F calibration made for static measurements is also valid for dynamic torque measurements.
- The natural frequency  $f_0$  for the mechanical measuring system depends on the moments of inertia  $J_1$  and  $J_2$  of the connected rotating masses and the T10F torsional stiffness.

Use the equation below to approximately determine the natural frequency  $f_0$  of the mechanical measuring arrangement:

$$f_0 = \frac{1}{2\pi} \cdot \sqrt{c_T \cdot \left( \frac{1}{J_1} + \frac{1}{J_2} \right)}$$

$f_0$	=	natural frequency in Hz
$J_1, J_2$	=	mass moment of inertia in kg·m <sup>2</sup>
$c_T$	=	torsional stiffness in N·m/rad

- The oscillation width (peak-to-peak) can be max. 160 % (for nominal (rated) torques 50 N·m=320 %, 10 kN·m=120%) of the nominal (rated) torque designated for the T10F, even under alternating load. The vibration bandwidth must fall within the loading bandwidth specified by  $-M_{nom}$  and  $+M_{nom}$  (at 50 N·m:  $-2 \cdot M_{nom} \dots +2 \cdot M_{nom}$ ). The same also applies to transient resonance points.

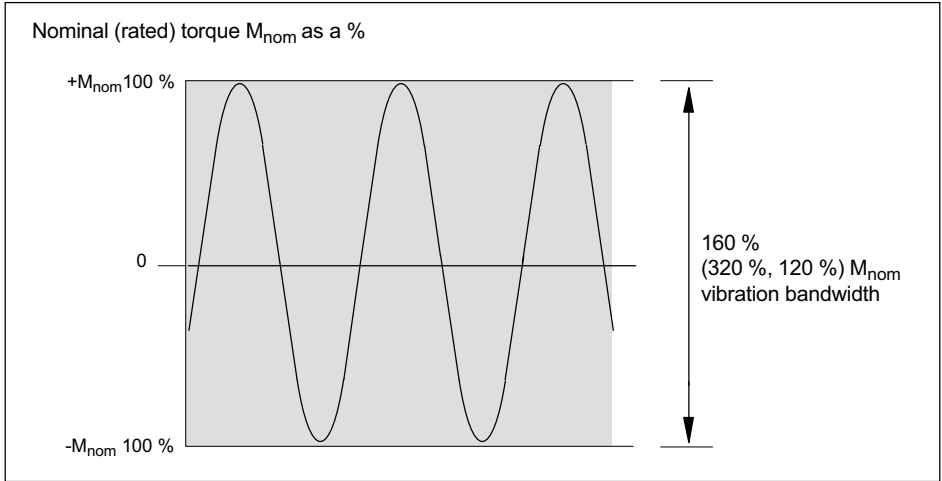

Fig. 10.1 Permissible dynamic loading

## 11 Maintenance

Torque measurement flanges are maintenance-free.

### 11.1 Speed module maintenance

During operation and depending on the ambient conditions, the slotted disc of the rotor and the associated stator sensor optics can get dusty. This will become noticeable when the polarity of the display changes. Should this occur, the sensor and the slotted disc must be cleaned.

1. Use compressed air (up to 6 bar) to clean the slotted disc.
2. Carefully clean the optical system of the sensor with a dry cotton bud or one soaked with pure spirit. *Do not use any other solvent!*

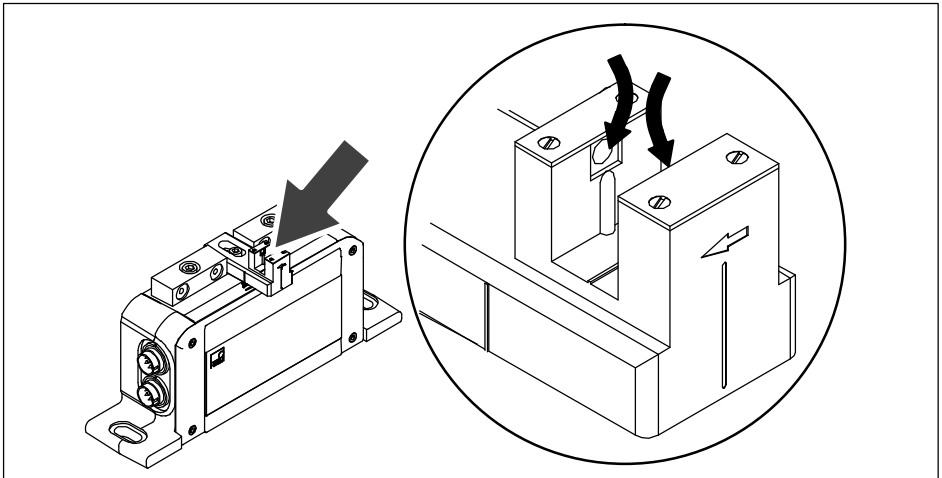
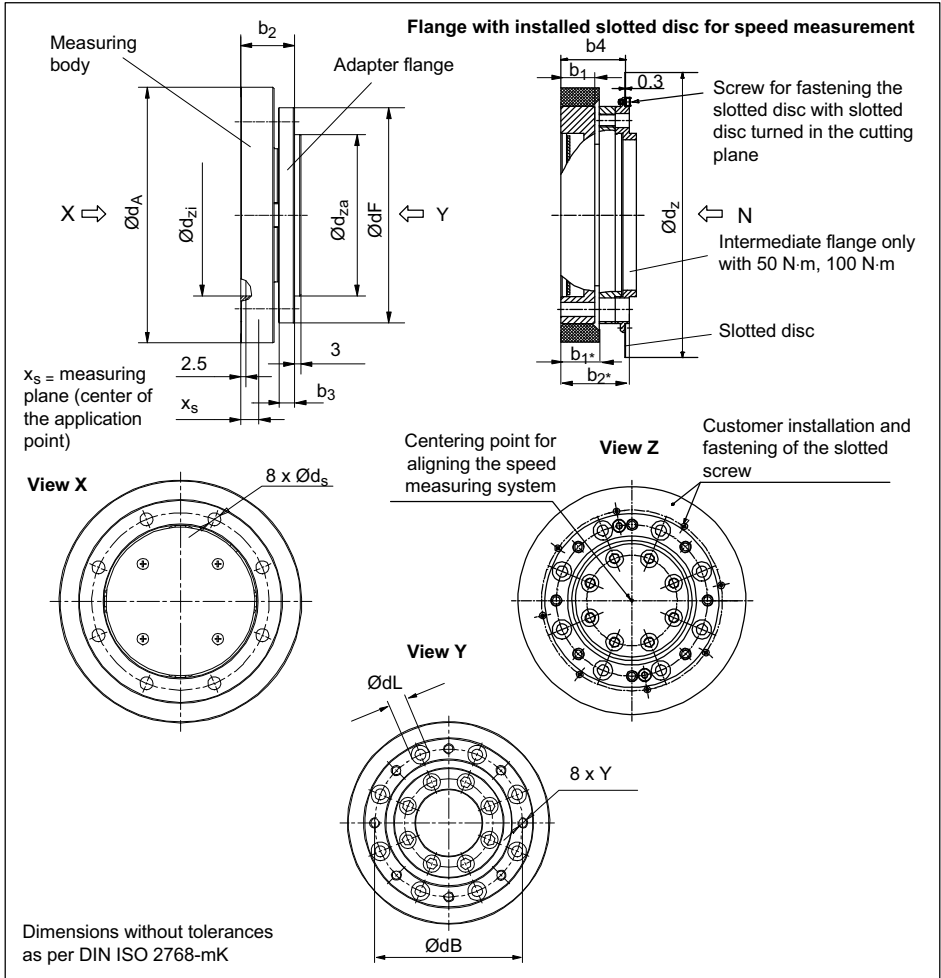

Fig. 11.1 Cleaning points on the speed sensor

# 12 Dimensions

## 12.1 Rotor dimensions



Measuring range	Dimensions (in mm; 1 mm = 0.03937 inches)															
	b <sub>1</sub>	b <sub>1*</sub>	b <sub>2</sub>	b <sub>2*</sub>	b <sub>3</sub>	b <sub>4</sub>	∅ <sub>d<sub>A</sub></sub>	∅ <sub>d<sub>B</sub></sub>	∅ <sub>d<sub>F</sub></sub>	∅ <sub>d<sub>L</sub></sub>	∅ <sub>d<sub>Z</sub></sub>	∅ <sub>d<sub>za</sub><sub>g5</sub></sub>	∅ <sub>d<sub>zi</sub><sub>H6</sub></sub>	∅ <sub>d<sub>s</sub></sub>	Y	X <sub>s</sub>
50 N·m	15.5	17.5	25	31.5	7.5	29.5	117	87	100	11	131	75	75	6.4	M6	13
100 N·m	15.5	17.5	25	31.5	7.5	29.5	117	87	100	11	131	75	75	6.4	M6	13
200 N·m	17.5	17.5	30.5	30.5	11	29.5	137	105	121	14	151	90	90	8.4	M8	14
500 N·m	20.5	20.5	40.5	40.5	18	33	173	133	156	20	187	110	110	13	M12	15.5
1 kN·m	20.5	20.5	40.5	40.5	18	33	173	133	156	20	187	110	110	13	M12	15.5
2 kN·m	22.5	22.5	42.5	42.5	18	35	207	165	191	24	221	140	140	15	M14	16.5
3 kN·m	27.0	22.5	55	55	26	35	207	165	191	24	221	140	140	15	M14	18.8
5 kN·m	28.5	28.5	64	64	33.5	41	254	206	238	30	269	174	174	19	M18	19.5
10 kN·m	33.5	28.5	69	69	33.5	41	254	206	238	30	269	174	174	19	M18	22.5

## 12.2 Stator dimensions

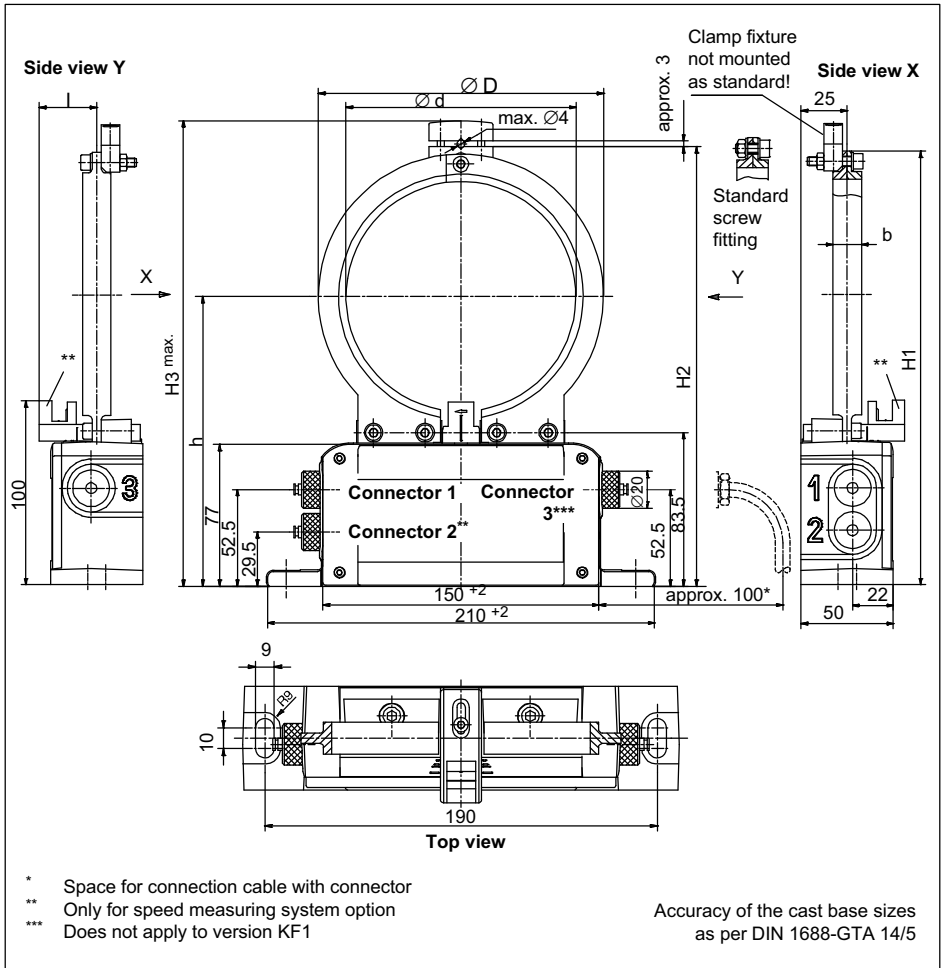



Measuring range	Dimensions (in mm; 1 mm = 0.03937 inches)							
	b	∅d	∅D	H1	H2	H3	h	l
50 N·m	15.5	125	155	235	239	253	157.5	31.5
100 N·m	15.5	125	155	235	239	253	157.5	31.5
200 N·m	17.5	145	175	255	259	273	167.5	31.5
500 N·m	20.5	181	211	291	295	309	185.5	33.5
1 kN·m	20.5	181	211	291	295	309	185.5	33.5
2 kN·m	22.5	215	245	325	329	343	202.5	34.5
3 kN·m	22.5	215	245	325	329	343	202.5	34.5
5 kN·m	28.5	262	292	373	377	391	226.5	37.5
10 kN·m	28.5	262	292	373	377	391	226.5	37.5

### 12.3 Mounting dimensions

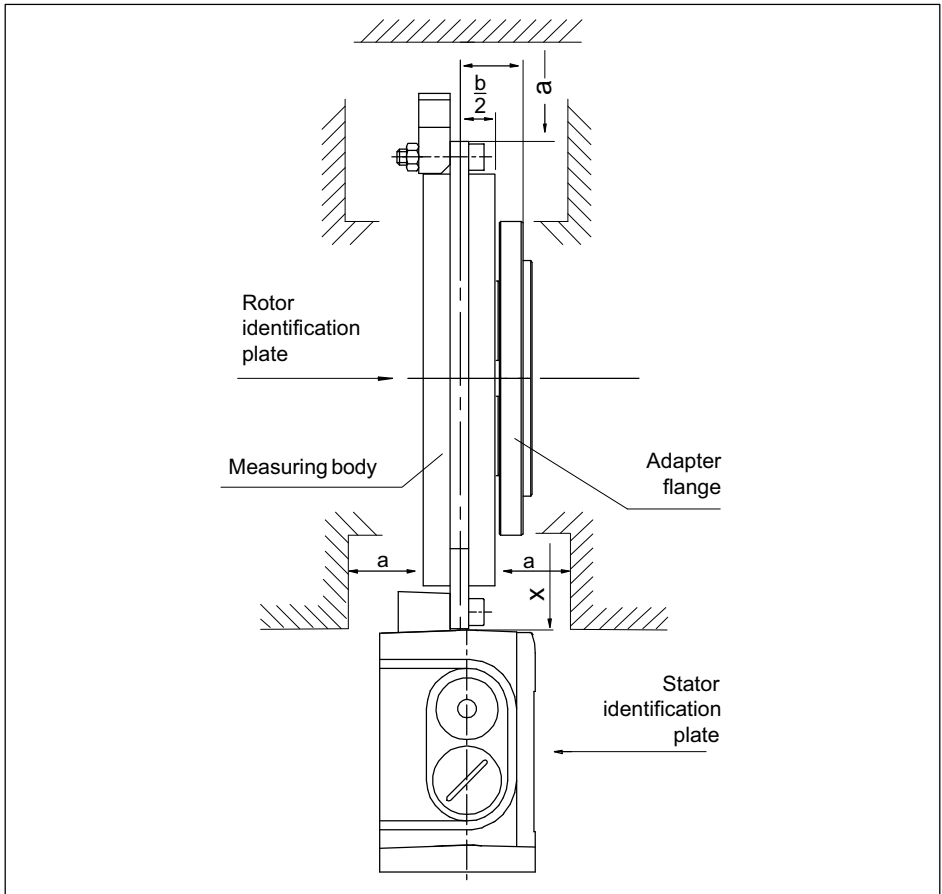

Mounting dimensions			
Measuring range	Dim. "m" (mm)	Area free of metal parts <sup>1)</sup> (mm)	
		a	x
50 N·m	16.25	20	29.5
100 N·m			
200 N·m	21.75	20	29
500 N·m	30.25	20	29.5
1 kN·m	30.25	20	29.5
2 kN·m	31.25	25	29
3 kN·m	43.75	25	29
5 kN·m	49.75	35	29.5
10 kN·m	54.75	35	29.5

1) Support with metal rod is permissible with the recommended dimensions

# 13 Order numbers, accessories

Code	Option 1: Measuring range
050Q	50 N·m
100Q	100 N·m
200Q	200 N·m
500Q	500 N·m
001R	1 kN·m
002R	2 kN·m
003R	3 kN·m
005R	5 kN·m
010R	10 kN·m

Code	Option 4: Speed measuring system <sup>2)</sup>
0	Without the speed measuring system
1	360 Pulses/revolution
2	180 Pulses/revolution
3	90 Pulses/revolution
4	60 Pulses/revolution
5	30 Pulses/revolution
6	15 Pulses/revolution
7	720 Pulses/revolution <sup>3)</sup>

Code	Option 2: Electrical configuration
KF1	Output signal 10 kHz ± 5 kHz, excitation voltage 14 kHz / 54 V; square wave
SF1	Output signal 10 kHz ± 5 kHz, supply voltage 18 ... 30 V DC
SU2	Output signal 10 kHz ± 5 kHz and ± 10 V, supply voltage 18 - 30 V DC

Code	Option 5: Connection cable
V0	Without connection cable
V1	Torque connection cable for KF1, 423 free ends, 6m
V2 <sup>*)</sup>	Torque connection cable for KF1, 423 free ends, max. 80 m
V3	Torque connection cable for KF1, 423 MS3106PEMV, 6m
V4 <sup>*)</sup>	Torque connection cable for KF1, 423 MS3106PEMV, max. 80 m
V5	Torque connection cable for SF1/SU2, 423 DSub 15P, 6m
V6 <sup>*)</sup>	Torque conn. cable for SF1/SU2, 423 D-Sub 15P, max. 50 m
W1	Torque and speed, one cable each, 423 D-Sub 15P, 6m
W2 <sup>*)</sup>	Torque and speed, one cable each, 423 D-Sub 15P, max. 50 m

Code	Option 3: Linearity deviation including hysteresis
S	<±0.1
G	<±0.05 <sup>1)</sup>

Code	Option 6: Mounted couplings type HK <sup>4)</sup>
N	Without coupling
Y	With coupling

Order number:

K-T10F - [ ] [ ] [ ] [ ] - [ ] [ ] [ ] [ ] - [ ] [ ] [ ] [ ] [ ] [ ] [ ] [ ] m<sup>5)</sup>

Ordering example:

K-T10F - [5] [0] [0] [Q] - [S] [F] [1] - [S] - [0] - [V] [5] - [Y] [ ] [ ] [ ] [ ] m<sup>5)</sup>

1) For voltage output <±0.07  
 2) For option 2, code SF1, SU2 only  
 3) Only with option 1, code 002R, 003R, 005R, 010R

4) Specifications, see data sheet B0120-x.x  
 5) With selections V2, V4, V6 and W2, please specify required length of cable.

**Accessories, to be ordered separately**

	<b>Order No.</b>
Cable socket 423G-7S, 7-pin, straight cable entry, for torque output (connectors 1, 3)	3-3101.0247
Cable socket 423W-7S, 7-pin, 90° cable entry, for torque output (connectors 1, 3)	3-3312.0281
Cable socket 423G-8S, 8-pin, straight cable entry, for speed output (connector 2),	3-3312.0120
Cable socket 423W-8S, 8-pin, 90° cable entry, for speed output (connector 2)	3-3312.0282
Kab8/00-2/2/2 by the meter	4-3301.0071

# 14 Specifications

<b>Type</b>		T10F								
<b>Accuracy class</b>		0.1								
<b>Torque measuring system</b>										
<b>Nominal (rated) torque</b> <b>M<sub>nom</sub></b>	<b>N-m</b>	<b>50</b>	<b>100</b>	<b>200</b>	<b>500</b>	<b>1k</b>	<b>2k</b>	<b>3k</b>	<b>5k</b>	<b>10k</b>
<b>Nominal (rated) sensitivity</b> (nominal (rated) signal range between torque = zero and nominal (rated) torque)										
Frequency output	kHz	5								
Voltage output	V	10								
<b>Sensitivity tolerance</b> (deviation of actual output quantity at M <sub>nom</sub> from nominal (rated) signal range)										
Frequency output	%	±0.1								
Voltage output	%	±0.2								
<b>Output signal at torque = zero</b>										
Frequency output	kHz	10								
Voltage output	V	0								
<b>Nominal output signal</b>										
<b>Frequency output</b>										
at positive nominal (rated) torque	kHz	15 (5 V symmetrical <sup>1</sup> )/12 V asymmetrical <sup>2</sup> )								
at negative nominal (rated) torque	kHz	5 (5 V symmetrical <sup>1</sup> )/12 V asymmetrical <sup>2</sup> )								
<b>Voltage output</b>										
at positive nominal (rated) torque	V	+10								
at negative nominal (rated) torque	V	-10								
<b>Load resistance</b>										
Frequency output	kΩ	≥2								
Voltage output	kΩ	≥5								
<b>Longterm drift over 48 h</b>										

Nominal (rated) torque $M_{nom}$	N·m	50	100	200	500	1k	2k	3k	5k	10k
Voltage output	mV	$\leq \pm 3$								
<b>Measurement frequency range</b>										
Voltage output	Hz	0 ... 1000 (-3 dB)								
<b>Group delay</b>										
Frequency output	ms	0.15								
Voltage output	ms	0.9								
<b>Residual ripple</b>										
Voltage output	%	0.4 (peak-to-peak)								
<b>Temperature effect per 10 K in the nominal (rated) temperature range</b>										
on the output signal, related to the actual value of the signal spread										
Frequency output	%	$< \pm 0.1$								
Voltage output	%	$< \pm 0.2$								
on the zero signal, related to the nominal (rated) sensitivity										
Frequency output	%	$< \pm 0.1$								$< \pm 0.05$
Voltage output	%	$< \pm 0.2$								$< \pm 0.15$
<b>Power supply (version KF1)</b>										
Excitation voltage (square wave)	V	$54 \pm 5\%$ (peak-to-peak)								
Calibration signal triggering	V	$80 \pm 5\%$								
Frequency	kHz	approx. 14								
Max. current consumption	A	1 (peak-to-peak)								
<b>Preamplifier excitation voltage</b>	V	0/0/+15								
<b>Preamplifier, max. current consumption</b>	mA	0/0/+25								
<b>Power supply (version SF1/SU2)</b>										

Nominal (rated) torque $M_{nom}$	N·m	50	100	200	500	1k	2k	3k	5k	10k	
Nominal (rated) supply voltage (separated extralow voltage (SELV))	V (DC)	18 ... 30; asymmetrical									
Current consumption in measuring mode	A	< 0.9									
Current consumption in startup mode	A	< 2									
<b>Nominal (rated) power consumption</b>	W	< 12									
<b>Linearity deviation including hysteresis, relative to the nominal (rated) sensitivity</b>											
Frequency output	%	< ± 0.1 (optional < ± 0.05)									
Voltage output	%	< ± 0.1 (optional < ± 0.07)									
<b>Rel. standard deviation of reproducibility</b> as per DIN 1319, relative to the variation of the output signal	%	< ± 0.03									
<b>Calibration signal</b>		approx. 50% of $M_{nom}$ ; more precise value on identification plate									
<b>Tolerance of the calibration signal</b>	%	< ± 0.05									
<b>Speed measuring system</b>											
<b>Measurement system</b>		Optical, by means of infrared light and metallic slotted disc									
<b>Mechanical increments</b>	No.	360					720				
<b>Positional tolerance of the increments</b>	mm	± 0.05									
<b>Slot width tolerance</b>	mm	± 0.05									
<b>Pulses per revolution adjustable</b>	No.	360; 180; 90; 60; 30; 15					720; 360; 180; 90; 60; 30; 15				
<b>Output signal</b>	V	5 symmetrical (complementary signals RS-422) 2 square-wave signals, approx. 90° phase-shifted									
<b>Load resistance</b>	kΩ	≥ 2									
<b>Minimum rotational speed for sufficient pulse stability</b>	min <sup>-1</sup>	2									



Nominal (rated) torque $M_{nom}$	N·m	50	100	200	500	1k	2k	3k	5k	10k
<b>Group delay</b>	µs	< 5 typ. 2.2								
<b>Max. permissible axial displacement of the rotor to the stator</b>	mm	± 2								
<b>Max. permissible radial shift of the rotor to the stator</b>	mm	± 1								
<b>Hysteresis of reversal<sup>3)</sup></b> in the case of relative vibrations between the rotor and the stator										
Torsional vibration of the rotor	Degr.	< approx. 2								
Radial vibration amplitude of the stator	mm	< approx. 2								
<b>Permitted degree of pollution</b> , in the optical path of the optical sensor (lenses, slotted disc)	%	< 50								
<b>Protection against ambient light</b>		By fork and infrared filter								
<b>General Information</b>										
<b>EMC</b>										
<b>Emission</b> (per FCC 47 Part 15, Subpart C)										
<b>Immunity from interference</b> (DIN EN50082-2)										
Electromagnetic field										
Housing	V/m	10								
Leads	V <sub>PP</sub>	10								
Magnetic field	A/m	100								
Burst	kV	2/1								
ESD	kV	4/8								
<b>Interference emission</b> (EN55011; EN55022; EN55014)										
RFI voltage		Class A								

Nominal (rated) torque $M_{nom}$	N·m	50	100	200	500	1k	2k	3k	5k	10k
RFI power		Class B								
RFI field strength		Class B								
<b>Degree of protection per EN 60529</b>		IP 54								
<b>Weight, approx.</b>										
Rotor	kg	0.9	0.9	1.8	3.5	3.5	5.8	7.8	14.0	15.2
Rotor with speed measuring system	kg	1.1	1.1	1.8	3.5	3.5	5.9	7.9	14.1	15.3
Stator	kg	1.1	1.1	1.2	1.2	1.2	1.3	1.3	1.4	1.4
<b>Reference temperature</b>	°C	+23								
<b>Nominal (rated) temp. range</b>	°C	+10...+60								
<b>Operating temperature range</b>	°C	-10...+60								
<b>Storage temperature range</b>	°C	-20...+70								
<b>Impact resistance, test severity level according to DIN IEC 68; Part 227; IEC 682271987</b>										
Number	n	1000								
Duration	ms	3								
Acceleration (half sine)	m/s <sup>2</sup>	650								
<b>Vibration resistance, test severity level per DIN IEC 68, Part 2-6: IEC 68-2-6-1982</b>										
Frequency range	Hz	5...65								
Duration	h	1.5								
Acceleration (amplitude)	m/s <sup>2</sup>	50								
<b>Nominal speed (x1000)</b>	min <sup>-1</sup>	15	15	15	12	12	10	10	8	8
<b>Load limits<sup>4)</sup></b>										
<b>Limit torque, related to <math>M_{nom}</math></b>	%	400	200						160	
<b>Breaking torque, related to <math>M_{nom}</math></b>	%	>800	>400						>300	
<b>Longitudinal limit force</b>	kN	2	2	4	7	7	12	14	22	31

Nominal (rated) torque $M_{nom}$	N·m	50	100	200	500	1k	2k	3k	5k	10k
Lateral limit force	kN	1	1	3	6	8	15	18	30	40
Bending limit moment	N·m	70	70	140	500	500	1000	1600	2500	4000
Oscillation width per DIN 50 100 (peaktopeak) <sup>5)</sup>	kN·m	0.16	0.16	0.32	0.8	1.6	3.2	4.8	8.0	12.0

- 1) RS-422 complementary signals; factory settings version SF1/SU2
- 2) Factory settings version KF1 (changeover not possible)
- 3) C can be switched off
- 4) Each type of irregular stress (bending moment, lateral or longitudinal force, exceeding nominal (rated) torque) can only be permitted up to its specified static load limit provided none of the others can occur at the same time. If this condition is not met, the limit values must be reduced. If 30% of the bending limit moment and lateral limit force occur at the same time, only 40% of the longitudinal limit force is permissible and the nominal (rated) torque must not be exceeded. The permissible bending moments, longitudinal forces and lateral forces can affect the measurement result by approx. 1 % of the nominal (rated) torque.
- 5) It is permissible to exceed the nominal (rated) torque by 100% with T10F/50 N·m, but the nominal torque may not be exceeded with T10F/100 N·m up to 10 kN·m.

Mechanical values 50 N·m ... 500 N·m					
Nominal (rated) torque $M_{nom}$	N·m	50	100	200	500
Torsional stiffness $c_T$	kN·m/ rad	160	160	430	1000
Torsion angle $M_{nom}$	Degree	0.018	0.036	0.027	0.028
Maximum deflection at longitudinal force limit	mm	< 0.03			
Additional max. radial run-out deviation at lateral limit force	mm	< 0.01			< 0.02
Additional plane/parallel deviation at bending moment limit	mm	< 0.2			
Balance quality level per DIN ISO 1940		G 6.3			
<b>Max. limits for relative rotor vibration displacement (peaktopeak)<sup>6)</sup></b> Undulations in area of connection flange, based on ISO 7919-3					
Normal operation (continuous operation)	μm	$s_{(p-p)} = \frac{9000}{\sqrt{n}} (n \text{ in } \text{min}^{-1})$			
Start and stop operation/resonance ranges (temporary)	μm	$s_{(p-p)} = \frac{13200}{\sqrt{n}} (n \text{ in } \text{min}^{-1})$			
<b>Mass moment of inertia of the rotor</b>					
$I_V$ (around axis of rotation) $\times 10^{-3}$	kg·m <sup>2</sup>	1.3	1.3	3.4	13.2
$I_V$ with speed system $\times 10^{-3}$	kg·m <sup>2</sup>	1.7	1.7	3.5	13.2
<b>Proportional mass moment of inertia (measuring body side)</b>	%	51	51	44	39
<b>Proportional mass moment of inertia with speed measuring system (measuring body side)</b>	%	40	40	43	39
<b>Max. permissible static eccentricity of the rotor (radially)<sup>7)</sup></b>	mm	$\pm 2$			
<b>Perm. axial displacement between rotor and stator<sup>7)</sup></b>	mm	$\pm 2$			$\pm 3$

6) The influence of radial run-out deviations, eccentricity, defects of form, notches, marks, local residual magnetism, structural variations or material anomalies needs to be taken into account and isolated from the actual wave oscillation.

7) Refer to limited values for speed measuring system

<b>Mechanical values 1 kN·m ... 10 kN·m</b>						
<b>Nominal (rated) torque <math>M_{nom}</math></b>	<b>N·m</b>	<b>1 k</b>	<b>2 k</b>	<b>3 k</b>	<b>5 k</b>	<b>10 k</b>
<b>Torsional stiffness <math>c_T</math></b>	kN·m/ rad	1800	3300	5100	9900	15000
<b>Torsion angle <math>M_{nom}</math></b>	Degree	0.032	0.034	0.034	0.029	0.038
<b>Maximum deflection at longitudinal force limit</b>	mm	< 0.03				
<b>Additional max. radial run-out deviation at lateral limit force</b>	mm	< 0.02		< 0.03		
<b>Additional plane/parallel deviation at bending moment limit</b>	mm	< 0.2				
<b>Balance quality level per DIN ISO 1940</b>		G 6.3				
<b>Max. limits for relative rotor vibration displacement (peaktopeak)<sup>8)</sup></b> Undulations in area of connection flange, based on ISO 7919-3						
Normal operation (continuous operation)	μm	$s_{(p-p)} = \frac{9000}{\sqrt{n}} (n \text{ in } \text{min}^{-1})$				
Start and stop operation/resonance ranges (temporary)	μm	$s_{(p-p)} = \frac{13200}{\sqrt{n}} (n \text{ in } \text{min}^{-1})$				
<b>Mass moment of inertia of the rotor</b>						
$I_V$ (around axis of rotation) x 10 <sup>-3</sup>	kg·m <sup>2</sup>	13.2	29.6	41	110	120
$I_V$ with speed system x 10 <sup>-3</sup>	kg·m <sup>2</sup>	13.2	29.6	41	110	120
<b>Proportional mass moment of inertia</b> (measuring body side)	%	39	38	33	31	33
<b>Proportional mass moment of inertia with speed measuring system</b> (measuring body side)	%	39	38	33	31	33
<b>Max. permissible static eccentricity of the rotor</b> (radially <sup>9)</sup> )	mm	± 2				
<b>Perm. axial displacement</b> between rotor and housing <sup>9)</sup> )	mm	± 3				

<sup>8)</sup> The influence of radial run-out deviations, eccentricity, defects of form, notches, marks, local residual magnetism, structural variations or material anomalies needs to be taken into account and isolated from the actual wave oscillation.

<sup>9)</sup> Refer to limited values for speed measuring system

## 15 Supplementary technical information

### 15.1 Output signals

#### 15.1.1 Output MD torque (connector 1)

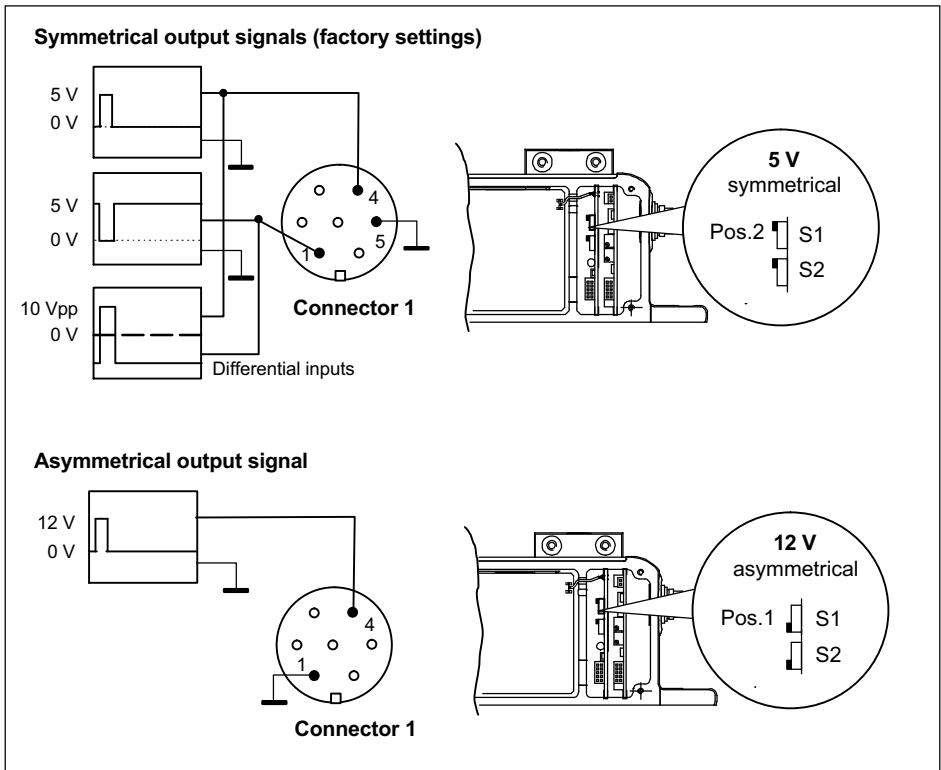

### 15.1.2 Output N: Speed (connector 2)

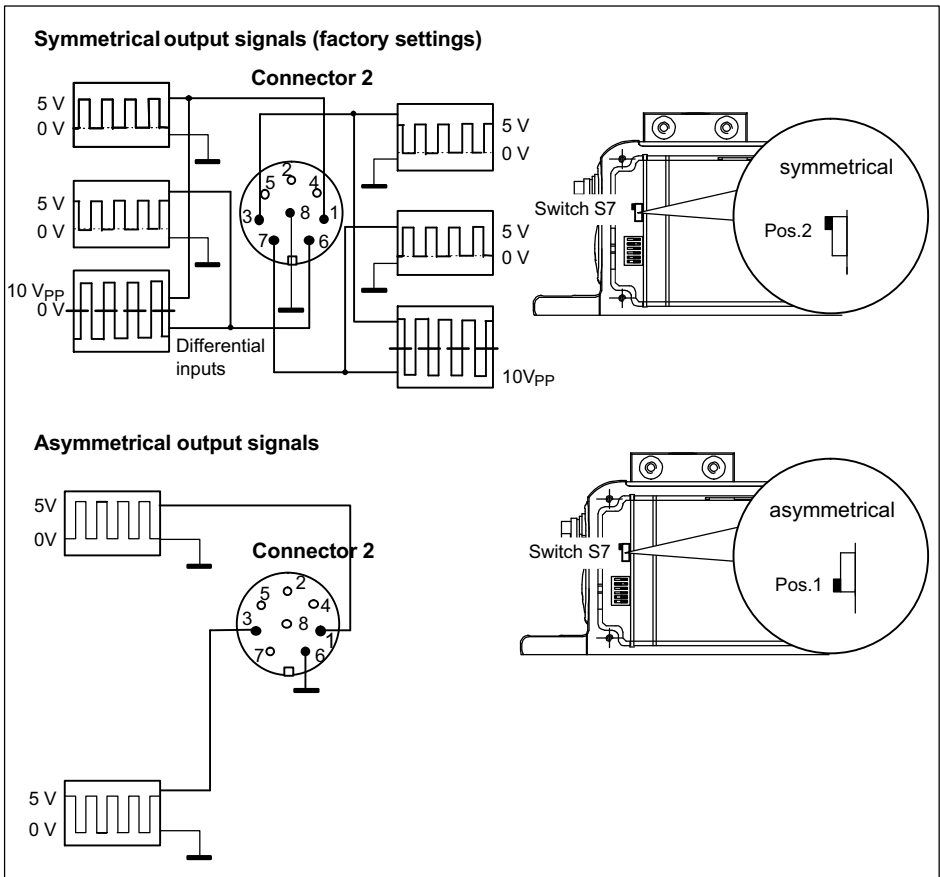

### 15.1.3 Connector 2, double frequency, stat. direction of rotation signal

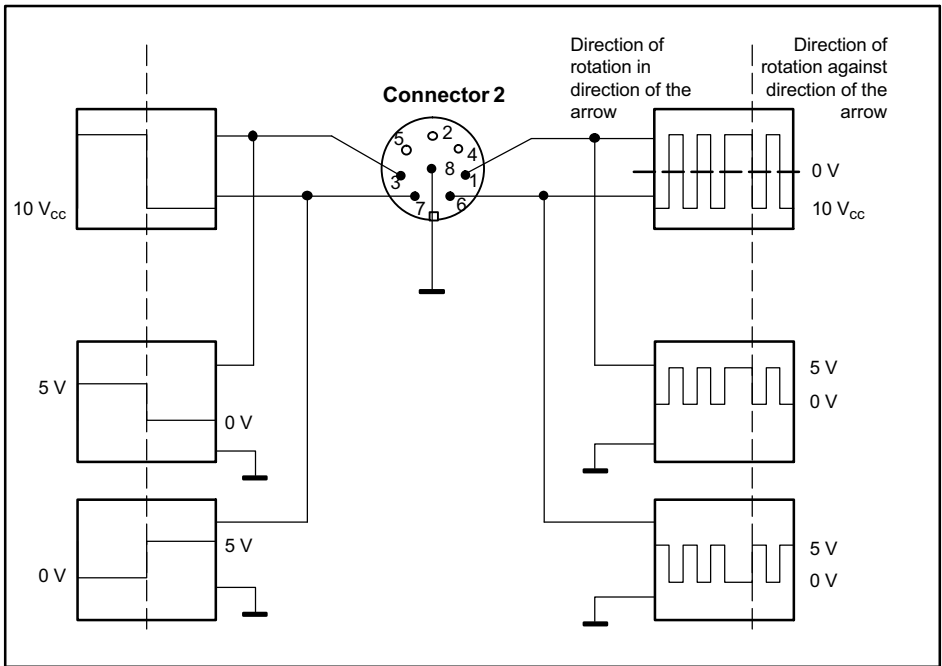



## 15.2 Axial and radial run-out tolerances

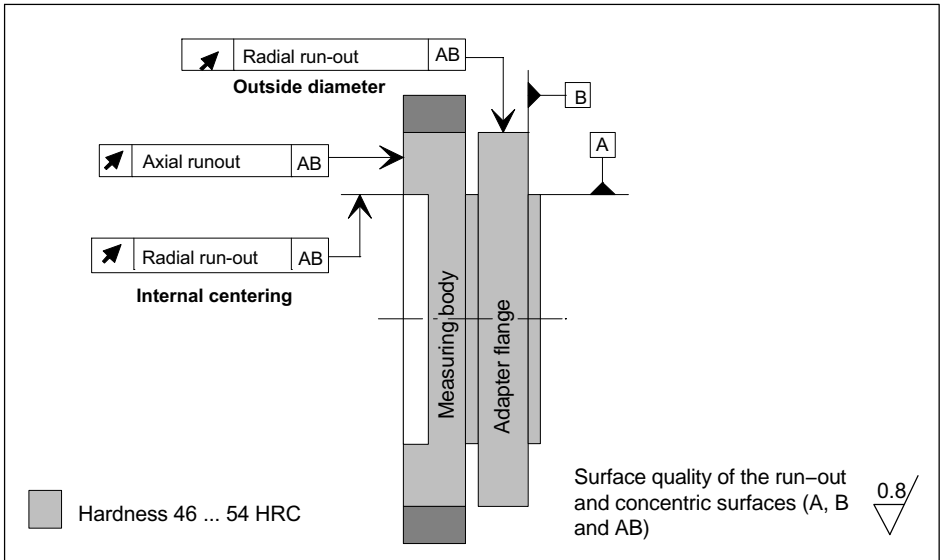

Measuring range	Axial runout tolerance (mm)	Radial run-out tolerance (mm)
50 N·m	0.02	0.02
100 N·m	0.02	0.02
200 N·m	0.02	0.02
500 N·m	0.02	0.02
1 kN·m	0.02	0.02
2 kN·m	0.04	0.04
3 kN·m	0.04	0.04
5 kN·m	0.04	0.04
10 kN·m	0.04	0.04

### 15.3 Additional mechanical data

Nominal (rated) torque $M_{nom}$	N·m	50	100	200	500	1 k	2 k	3 k	5 k	10 k
<b>Mechanical values</b>										
Stiffness in the axial direction $c_a$	kN/mm	90	90	190	410	430	500	900	1200	2100
Stiffness in the radial direction $c_r$	kN/mm	200	200	280	430	440	750	820	1000	1430
Stiffness during the bending moment around a radial axis $c_b$	kN·m/deg.	0.9	0.9	2.7	8.8	9.1	18.3	37.5	69.0	142
	kN·m/rad	51	51	155	510	520	1050	2150	3950	8000



**HBM Test and Measurement**

Tel. +49 6151 803-0

Fax +49 6151 803-9100

info@hbm.com

measure and predict with confidence



A0608-17.0 7-2001.1510 HBM: public

www.hbm.com